

TB 9-6625-2343-50

DEPARTMENT OF THE ARMY TECHNICAL BULLETIN

CALIBRATION PROCEDURE FOR MEASURING RECEIVER HEWLETT-PACKARD MODEL 8902A

Headquarters, Department of the Army, Washington, DC

16 July 2003

Approved for public release; distribution is unlimited.

REPORTING OF ERRORS AND RECOMMENDING IMPROVEMENTS

You can improve this manual. If you find any mistakes or if you know of a way to improve these procedures, please let us know. Mail your letter or DA Form 2028 (Recommended Changes to Publications and Blank Forms) directly to: Commander, U.S. Army Aviation and Missile Command, ATTN: AMSAM-MMC-MA-NP, Redstone Arsenal, AL 35898-5000. A reply will be furnished to you. You may also provide DA Form 2028 information to AMCOM via email, fax, or the World Wide Web. Our fax number is DSN 788-6546 or Commercial 256-842-6546. Our e-mail address is: 2028@redstone.army.mil. Instructions for sending an electronic 2028 may be found at the back of this manual. For the World Wide Web, use <https://amcom2028.redstone.army.mil>.

SECTION		Paragraph	Page
I.	IDENTIFICATION AND DESCRIPTION		
	Test instrument identification	1	2
	Forms, records, and reports.....	2	2
	Calibration description	3	2
II.	EQUIPMENT REQUIREMENTS		
	Equipment required	4	5
	Accessories required	5	6
III.	CALIBRATION PROCESS		
	Preliminary instructions	6	7
	Equipment setup	7	8
	Amplitude modulation	8	8
	Frequency modulation.....	9	16
	Phase modulation.....	10	24
	Audio filters.....	11	28
	Audio measurements.....	12	30
	Power reference.....	13	35
	Power meter	14	37
	SWR test	15	40
	Tuned level RF.....	16	44
	High select filters.....	17	47
	Power supplies.....	18	51
	Final procedure.....	19	53

**SECTION I
IDENTIFICATION AND DESCRIPTION**

1. Test Instrument Identification. This bulletin provides instructions for the calibration of Measuring Receiver, Hewlett-Packard Model 8902A. The manufacturer's manual was used as the prime data source in compiling these instructions. The equipment being calibrated will be referred to as the TI (test instrument) throughout this bulletin.

a. Model Variations. None

b. Time and Technique. The time required for this calibration is approximately 8 hours, using the dc and low frequency technique.

2. Forms, Records, and Reports

a. Forms, records, and reports required for calibration personnel at all levels are prescribed by TB 750-25.

b. Adjustments to be reported are designated ® at the end of the sentence in which they appear. When adjustments are in tables, the ® follows the designated adjustment. Report only those adjustments made and designated with ®.

3. Calibration Description. TI parameters and performance specifications which pertain to this calibration are listed in table 1.

Table 1. Calibration Description

Test instrument parameters	Performance specifications
Amplified Modulation	Range: 0 to 99%
	Accuracy: ±2% of reading ±1 digit
	Carrier: 150 kHz to 10 MHz
	Rate: 50 Hz to 10 kHz
	Depth: 5 to 99%
	Accuracy: ±3% of reading ±1 digit
	Carrier: 150 kHz to 10 MHz
	Rate: 20 Hz to 10 kHz
	Depth: to 99%
	Accuracy: ±1% of reading ±1 digit
Carrier: 10MHz to 1.3 GHz	
Rate: 50 Hz to 50 kHz	
Depth: 5 to 99%	
Accuracy: ±3% of reading ±1 digit	
Carrier: 10 MHz to 1.3 GHz	
Rate: 20Hz to 100 kHz	
Depth: to 99%	
Flatness:	
Accuracy: ±0.3% of reading ±1 digit	
Carrier: 10 MHz to 1.3 GHz	
Rate: 90 Hz to 10 kHz	
Depth: 20 to 80%	
Demodulated output distortion:	
Accuracy:	
< 0.3% THD < 50% depth	
< 0.6% THD < 95% depth	
Residual AM:	
Accuracy:	
< 0.01% rms 50 Hz to 3 kHz bandwidth	
FM rejection :	
< 0.2% AM, 250 kHz to 10 MHz carrier; < 5 kHz peak deviation; 400 Hz and 1 kHz rates; 50 Hz to 3 kHz bandwidth	
< 0.2% AM, 10 MHz to 1.3 GHz carrier; < 50 kHz peak deviation; 400 Hz and 1 kHz rates; 50 Hz to 3 kHz bandwidth	

Table 1. Calibration Description - Continued

Test instrument parameters	Performance specifications																																																
Frequency Modulation	<p>Rates: 20 Hz to 10 kHz, 150 kHz to 10 MHz carrier; 20 Hz to 200 kHz, 10 MHz to 1.3 GHz carrier; 20 Hz to 20 kHz, 10 MHz to 1.3 GHz carrier w/750 μs de-emphasis filter</p> <hr/> <p>Deviation: 40 kHz pk max, 150 Hz to 10 MHz carrier; 400 kHz pk max, 10 MHz to 1.3 GHz carrier; 40 kHz pk max, 10 MHz to 1.3 GHz carrier w/750 μs de-emphasis filter</p> <hr/> <p>Accuracy:</p> <table border="0"> <thead> <tr> <th>Accuracy:</th> <th>Carrier:</th> <th>Rate:</th> <th>Deviation:</th> </tr> </thead> <tbody> <tr> <td>±2% of reading ±1 digit</td> <td>250 kHz to 10 MHz</td> <td>20 Hz to 10 kHz</td> <td><40 kHz pk</td> </tr> <tr> <td>±1% of reading ±1 digit</td> <td>10 MHz to 1.3 GHz</td> <td>50 Hz to 100 kHz</td> <td><400 kHz pk</td> </tr> <tr> <td>±1% of reading ±1 digit</td> <td>10 MHz to 1.3 GHz</td> <td>50 Hz to 100 kHz</td> <td><40 kHz pk 750 μs de-emphasis</td> </tr> <tr> <td>±5% of reading ±1 digit</td> <td>10 MHz to 1.3 GHz</td> <td>20 Hz to 200 kHz</td> <td><400 kHz pk</td> </tr> <tr> <td>±5% of reading ±1 digit</td> <td>10 MHz to 1.3 GHz</td> <td>20 Hz to 200 kHz</td> <td><40 kHz pk 750 μs de-emphasis</td> </tr> </tbody> </table> <hr/> <p>Demodulated output distortion:</p> <table border="0"> <thead> <tr> <th>THD:</th> <th>Carrier:</th> <th>Rate:</th> <th>Deviation:</th> </tr> </thead> <tbody> <tr> <td>< 0.1%</td> <td>400 kHz to 10 MHz</td> <td>20 Hz to 10 kHz</td> <td>< 10 kHz pk</td> </tr> <tr> <td>< 0.1%</td> <td>10 MHz to 1.3 GHz</td> <td>20 Hz to 100 kHz</td> <td>< 100 kHz pk</td> </tr> <tr> <td>< 0.1%</td> <td>10 MHz to 1.3 GHz</td> <td>20 Hz to 100 kHz</td> <td><40 kHz pk 750 μs de-emphasis</td> </tr> </tbody> </table> <hr/> <p>Residual FM: < 8 Hz rms at 1.3 GHz, decreasing linearly with frequency to < 1 Hz rms for =100 MHz, 50 Hz to 300 kHz bandwidth</p> <hr/> <p>AM rejection:</p> <table border="0"> <thead> <tr> <th>Rejection:</th> <th>Carrier:</th> <th>Rate:</th> <th>AM depth:</th> </tr> </thead> <tbody> <tr> <td>< 20 Hz pk deviation</td> <td>150 kHz to 1.3 GHz</td> <td>400 Hz or 1 kHz</td> <td>= 50%</td> </tr> </tbody> </table>	Accuracy:	Carrier:	Rate:	Deviation:	±2% of reading ±1 digit	250 kHz to 10 MHz	20 Hz to 10 kHz	<40 kHz pk	±1% of reading ±1 digit	10 MHz to 1.3 GHz	50 Hz to 100 kHz	<400 kHz pk	±1% of reading ±1 digit	10 MHz to 1.3 GHz	50 Hz to 100 kHz	<40 kHz pk 750 μs de-emphasis	±5% of reading ±1 digit	10 MHz to 1.3 GHz	20 Hz to 200 kHz	<400 kHz pk	±5% of reading ±1 digit	10 MHz to 1.3 GHz	20 Hz to 200 kHz	<40 kHz pk 750 μs de-emphasis	THD:	Carrier:	Rate:	Deviation:	< 0.1%	400 kHz to 10 MHz	20 Hz to 10 kHz	< 10 kHz pk	< 0.1%	10 MHz to 1.3 GHz	20 Hz to 100 kHz	< 100 kHz pk	< 0.1%	10 MHz to 1.3 GHz	20 Hz to 100 kHz	<40 kHz pk 750 μs de-emphasis	Rejection:	Carrier:	Rate:	AM depth:	< 20 Hz pk deviation	150 kHz to 1.3 GHz	400 Hz or 1 kHz	= 50%
Accuracy:	Carrier:	Rate:	Deviation:																																														
±2% of reading ±1 digit	250 kHz to 10 MHz	20 Hz to 10 kHz	<40 kHz pk																																														
±1% of reading ±1 digit	10 MHz to 1.3 GHz	50 Hz to 100 kHz	<400 kHz pk																																														
±1% of reading ±1 digit	10 MHz to 1.3 GHz	50 Hz to 100 kHz	<40 kHz pk 750 μs de-emphasis																																														
±5% of reading ±1 digit	10 MHz to 1.3 GHz	20 Hz to 200 kHz	<400 kHz pk																																														
±5% of reading ±1 digit	10 MHz to 1.3 GHz	20 Hz to 200 kHz	<40 kHz pk 750 μs de-emphasis																																														
THD:	Carrier:	Rate:	Deviation:																																														
< 0.1%	400 kHz to 10 MHz	20 Hz to 10 kHz	< 10 kHz pk																																														
< 0.1%	10 MHz to 1.3 GHz	20 Hz to 100 kHz	< 100 kHz pk																																														
< 0.1%	10 MHz to 1.3 GHz	20 Hz to 100 kHz	<40 kHz pk 750 μs de-emphasis																																														
Rejection:	Carrier:	Rate:	AM depth:																																														
< 20 Hz pk deviation	150 kHz to 1.3 GHz	400 Hz or 1 kHz	= 50%																																														

Table 1. Calibration Description - Continued

Test instrument parameters	Performance specifications																																												
	<p style="text-align: center;">Phase Modulation Deviation and Maximum Resolution</p>																																												
Audio filters	<table border="0" style="width: 100%;"> <tr> <td></td> <td style="text-align: center;"><u>Flatness:</u></td> <td style="text-align: center;"><u>Rate:</u></td> </tr> <tr> <td>50 Hz High-Pass filter (2 pole):</td> <td style="text-align: center;">< 1%</td> <td style="text-align: center;">≥200 Hz</td> </tr> <tr> <td>300 Hz High-Pass filter (2 pole)</td> <td style="text-align: center;">< 1%</td> <td style="text-align: center;">≥1 kHz</td> </tr> <tr> <td>3 kHz :Low-Pass Filter (5 pole)</td> <td style="text-align: center;">< 1%</td> <td style="text-align: center;">≤1 kHz</td> </tr> <tr> <td>15 kHz Low-Pass filter (5 pole):</td> <td style="text-align: center;">< 1%</td> <td style="text-align: center;">= 10 kHz</td> </tr> <tr> <td>>20 kHz Low-Pas filter (9 pole</td> <td style="text-align: center;">< 1%</td> <td style="text-align: center;">= 10 kHz</td> </tr> <tr> <td>Bessel</td> <td></td> <td></td> </tr> </table>		<u>Flatness:</u>	<u>Rate:</u>	50 Hz High-Pass filter (2 pole):	< 1%	≥200 Hz	300 Hz High-Pass filter (2 pole)	< 1%	≥1 kHz	3 kHz :Low-Pass Filter (5 pole)	< 1%	≤1 kHz	15 kHz Low-Pass filter (5 pole):	< 1%	= 10 kHz	>20 kHz Low-Pas filter (9 pole	< 1%	= 10 kHz	Bessel																									
	<u>Flatness:</u>	<u>Rate:</u>																																											
50 Hz High-Pass filter (2 pole):	< 1%	≥200 Hz																																											
300 Hz High-Pass filter (2 pole)	< 1%	≥1 kHz																																											
3 kHz :Low-Pass Filter (5 pole)	< 1%	≤1 kHz																																											
15 kHz Low-Pass filter (5 pole):	< 1%	= 10 kHz																																											
>20 kHz Low-Pas filter (9 pole	< 1%	= 10 kHz																																											
Bessel																																													
Audio Frequency Counter	<table border="0" style="width: 100%;"> <tr> <td colspan="4">Range: 20 Hz to 250 kHz</td> </tr> <tr> <td>Accuracy:</td> <td>Rate:</td> <td>Modulation:</td> <td>Level:</td> </tr> <tr> <td>Ref. accuracy ±3 digits</td> <td>> 1 kHz</td> <td>AM; = 10%</td> <td>>100</td> </tr> <tr> <td></td> <td></td> <td>FM; = 1.0 kHz</td> <td>mVrms</td> </tr> <tr> <td></td> <td></td> <td>PM; = 1.5 radians</td> <td>external</td> </tr> <tr> <td>Ref. accuracy ±0.02 Hz</td> <td>=1 kHz</td> <td>AM; = 10%</td> <td>>100</td> </tr> <tr> <td></td> <td></td> <td>FM; = 1.0 kHz</td> <td>mVrms</td> </tr> <tr> <td></td> <td></td> <td>PM; = 1.5 radians</td> <td>external</td> </tr> <tr> <td>Ref. accuracy ±0.2 Hz</td> <td>= 3 kHz</td> <td>AM; = 10%</td> <td>>100</td> </tr> <tr> <td>(3 kHz LP filter</td> <td></td> <td>FM; 0.15 kHz to < 1 kHz</td> <td>mVrms</td> </tr> <tr> <td>inserted)</td> <td></td> <td>PM; 0.15 rad to < 1.5 rad</td> <td>external</td> </tr> </table>	Range: 20 Hz to 250 kHz				Accuracy:	Rate:	Modulation:	Level:	Ref. accuracy ±3 digits	> 1 kHz	AM; = 10%	>100			FM; = 1.0 kHz	mVrms			PM; = 1.5 radians	external	Ref. accuracy ±0.02 Hz	=1 kHz	AM; = 10%	>100			FM; = 1.0 kHz	mVrms			PM; = 1.5 radians	external	Ref. accuracy ±0.2 Hz	= 3 kHz	AM; = 10%	>100	(3 kHz LP filter		FM; 0.15 kHz to < 1 kHz	mVrms	inserted)		PM; 0.15 rad to < 1.5 rad	external
Range: 20 Hz to 250 kHz																																													
Accuracy:	Rate:	Modulation:	Level:																																										
Ref. accuracy ±3 digits	> 1 kHz	AM; = 10%	>100																																										
		FM; = 1.0 kHz	mVrms																																										
		PM; = 1.5 radians	external																																										
Ref. accuracy ±0.02 Hz	=1 kHz	AM; = 10%	>100																																										
		FM; = 1.0 kHz	mVrms																																										
		PM; = 1.5 radians	external																																										
Ref. accuracy ±0.2 Hz	= 3 kHz	AM; = 10%	>100																																										
(3 kHz LP filter		FM; 0.15 kHz to < 1 kHz	mVrms																																										
inserted)		PM; 0.15 rad to < 1.5 rad	external																																										
Audio Distortion	<p>Frequencies: 400 Hz ±5%, 1 kHz ±5%</p> <p>Residual noise and distortion: 20 Hz to 50 kHz bandwidth < 0.3% (-50.4 dB)</p> <p>Accuracy: ±1 dB of reading</p> <p>Sensitivity:</p> <table border="0" style="width: 100%;"> <tr> <td style="text-align: center;">AM:</td> <td style="text-align: center;">FM:</td> <td style="text-align: center;">PM:</td> <td style="text-align: center;">Level:</td> </tr> <tr> <td style="text-align: center;">1.5% peak</td> <td style="text-align: center;">150 Hz peak</td> <td style="text-align: center;">0.6 rad peak</td> <td style="text-align: center;">0.1 to 3 Vrms</td> </tr> </table>	AM:	FM:	PM:	Level:	1.5% peak	150 Hz peak	0.6 rad peak	0.1 to 3 Vrms																																				
AM:	FM:	PM:	Level:																																										
1.5% peak	150 Hz peak	0.6 rad peak	0.1 to 3 Vrms																																										
Audio RMS Level	<p>Frequency range: 50 Hz to 40 kHz</p> <p>Voltage range: 100 mV to 3 V</p> <p>Accuracy: ±4% of reading</p>																																												
Power Reference	<p>Power output: 1.00 mW ±1.2%</p>																																												

Table 1. Calibration Description - Continued

Test instrument parameters	Performance specifications
SWR	RF power input: <1.15 using HP 11722A Sensor Tuned RF level input: < 1.18 at RF input, ranges 1 and 2 < 1.40 at RF input, range 3 < 1.33 at HP 11722A RF input, ranges 1 and 2 < 1.50 at HP 11722A RF input, range 3 < 1.33 at HP 11722A RF input , range 3 using special function 1.9
Tuned RF Level	Frequency range: 2.5 MHz to 1.3 GHz Power range: 0 to -127 dBm using IF Sync. Detector 0 to -100 dBm using IF Avg. Detector Detector linearity: ±0.02 dB IF sync. detector ±0.04 dB IF avg. detector IF Range to range error: ±0.02 dB/IF range change 1 to 5 ±0.05 dB/IF range change 6 to 7 Frequency drift error: ±0.05 dB/kHz frequency drift from center of IF Noise error: ±0.18 dB
High Selectivity Filters	Reference manufacturer's manual table 1-1
High Selectivity Gain	Frequency range: 10 MHz to 1.3 GHz Carrier power range: +30 to -20 dBm (12.5, 25, and 30 kHz filters) +30 to -10 dBm (carrier noise filter) Relative measurement: Accuracy: Level: Filters: ±0.5 dB > -95 dBc 12.5 kHz, 25 kHz, 30 kHz ±0.5 dB > -129 dBc carrier noise

**SECTION II
EQUIPMENT REQUIREMENTS**

4. Equipment Required. Table 2 identifies the specific equipment to be used in this calibration procedure. This equipment is issued with Secondary Reference Standards Set, NSN 4931-00-621-7878. Alternate items may be used by the calibrating activity. The items selected must be verified to perform satisfactorily prior to use and must bear evidence of current calibration. The equipment must meet or exceed the minimum use specifications listed in table 2. The accuracies listed in table 2 provide a four-to-one ratio between the standard and TI.

TB 9-6625-2343-50

5. Accessories Required. The accessories required for this calibration are common usage accessories, issued as indicated in paragraph 4 above, and are not listed in this calibration procedure.

Table 2. Minimum Specifications of Equipment Required

Common name	Minimum use specifications	Manufacturer and model (part number)
AM/FM TEST SOURCE	Range: AM; 0 to 95% Carrier; 12.5 MHz Rate; 10 Hz to 10 MHz	Hewlett-Packard, Model 11715A (11715A)
ATTENUATOR FIXED 6 dB	Range: 6 dB Frequency: 2.5 MHz to 1.3 GHz	Weinschel, Model 9918, 9918-3dB, 9918-6dB, 9918-10dB, 9918-20dB, 9918-30dB, and 9918-60dB (9918)
AUDIO ANALYZER	Output: Freq; 50 Hz to 40 kHz Ampl; 100 mV to 3 V Output Accuracy: ±1% Measurement: Distn; <0.025% Capability	Boonton, Model 1121 (1121)
CALIBRATOR	Frequency range: 20 Hz to 30 MHz Output range: 1 mV to 3VAC	John Fluke, Model 5720A/CT (p/o MIS-35947); w/power amplifier, John Fluke 5725A (5725A); w/ac divider, John Fluke, Model 7405A-2407 (7405A-4207)
DIGITAL MULTIMETER	Range: 0 to 50 VDC Accuracy: ±0.015%	John Fluke, Model 8840A/AF-05/09 (AN/GSM-64D)
MEASURING SYSTEM	Power output: 1mW @ 50 MHz Accuracy: ±0.3%	Argo Systems, Model AS1210-SA (MIS-35943)
OSCILLOSCOPE	Range: Vert; 0.02V/div Horiz; 10 µs/div	Tektronix, Type 2430A (OS-291/G)
PISTON ATTENUATOR	Range: 20 to 80 dB Accuracy: Test report values	Weinschel, Model PA-2 (PA-2)
RANGE CALIBRATOR	Range: 10 µW to 100 mW Accuracy: ±0.025%	Hewlett-Packard, Model 11683A (11683A)
SIGNAL GENERATOR NO. 1	Frequency range: 0.5 to 1100 MHz Output level: +19 dBm to 500 MHz +13 dBm to 1100 MHz Modulation Capability: AM and FM AM; 0 to 95% FM Range; 0 to 400 kHz pk. deviation Accuracy: AM; ±10% FM; ±10%	(SG-1207/U)

Table 2. Minimum Specifications of Equipment Required - Continued

Common name	Minimum use specifications	Manufacturer and model (part number)
SIGNAL GENERATOR NO. 2	Frequency range: 0.5 to 1100 MHz Output level: +19 dBm to 500 MHz +13 dBm to 1100 MHz Modulation Capability: AM and FM AM; 0 to 95% FM Range; 0 to 400 kHz pk. deviation Accuracy: AM; ±10% FM; ±10%	(SG-1207/U)
SIGNAL GENERATOR NO. 3	Used with test instrument as oscillator	(SG-1219/U) or Anritsu, Model 68369NV (68369NV)
SPECTRUM ANALYZER	Frequency: 0 to 2 GHz Input level: ±10 dBm Display range: 60 dB	(AN/USM-489A)
SWR BRIDGE	Range: 150 kHz to 1.3 GHz	Wiltron, Model 60NF50 (60NF50)
SYNTHESIZER/FUNCTION GENERATOR	Frequency range: 20 Hz to 250 kHz Amplitude range: 100 mV to 3.0 V Accuracy: ±0.005 Hz	Hewlett-Packard, Model 33250 (33250)

**SECTION III
CALIBRATION PROCESS**

6. Preliminary Instructions

a. The instructions outlined in paragraphs **6** and **7** are preparatory to the calibration process. Personnel should become familiar with the entire bulletin before beginning the calibration.

b. Items of equipment used in this procedure are referenced within the text by common name as listed in table 2.

c. Unless otherwise specified, verify the result of each test and, whenever the test requirement is not met, take corrective action before continuing with the calibration. Adjustments required to calibrate the TI are included in this procedure. Additional maintenance information is contained in the manufacturer’s manual.

d. Unless otherwise specified, all control and control settings refer to the TI.

7. Equipment Setup

WARNING

HIGH VOLTAGE is used or exposed during the performance of this calibration. DEATH ON CONTACT may result if personnel fail to observe safety precautions. REDUCE OUTPUT(S) to minimum after each step within the performance check where applicable.

NOTE

BEFORE CONNECTING TI, the protective earth terminal of the instrument must be connected to the protective conductor of the line power cord. The line plug shall only be inserted into a socket outlet provided with a protective earth contact. The protective action must not be negated by the use of an extension cord (power cable) without a protective conductor (grounding). Grounding one conductor of a two conductor outlet is not sufficient protection.

NOTE

When indications specified in this procedure are not within tolerance, perform the power supply check prior to making adjustments.

- a.** Connect TI to 115 V ac power source.
- b.** Press power key to on and allow at least 30 minutes for TI to warm up and stabilize.

8. Amplitude Modulation

a. Performance Check

NOTE

In the following procedure, any source can be connected either to a sensor module (as written) or directly to the TI **INPUT 50?** .

- (1) Press TI **BLUE** key and then press TI **INSTR PRESET** key.
- (2) Connect TI **CALIBRATION AM/FM OUTPUT** to TI sensor module.
- (3) Press TI keys as listed in (a) and (b) below:
 - (a) **MEASUREMENT AM.**
 - (b) **CALIBRATION CALIBRATE.**
- (4) Allow TI to take at least two readings. If TI indication is not between 99 and 101 percent, perform **b** below.

- (5) Press TI keys as listed in (a) and (b) below:
 - (a) **DATA 2.2.**
 - (b) **DATA SPCL.**
- (6) Allow TI to take at least two readings and record this reading. If TI indication is not between 99 and 101 percent, perform **b** below.

NOTE

Record indication in step (6) for future reference.

- (7) Set the AM/FM test source **TEST MODE** switch to **AM**.
- (8) Connect AM/FM test source **AM OUTPUT** to TI sensor module.

NOTE

Nothing should be connected to the **AUDIO INPUT** of the test source

- (9) Press TI keys as listed in (a) and (b) below:
 - (a) **MEASUREMENT FREQ.**
 - (b) **TRACK MODE.**
- (10) Adjust AM/FM test source **CARRIER FREQUENCY TUNE** control for a TI indication of approximately 12.5 MHz.
- (11) Press TI keys as listed in (a) through (f) below:
 - (a) **TRACK MODE.**
 - (b) **MEASUREMENT AM.**
 - (c) **DATA 2.0, SPCL.**
 - (d) **HP FILTER 50 Hz.**
 - (f) **DETECTOR AVG.**
 - (e) **LP FILTER 3 kHz.**
- (12) If TI indication is not = 0.01%, perform **b** below.
- (13) Connect equipment as shown in figure 1.

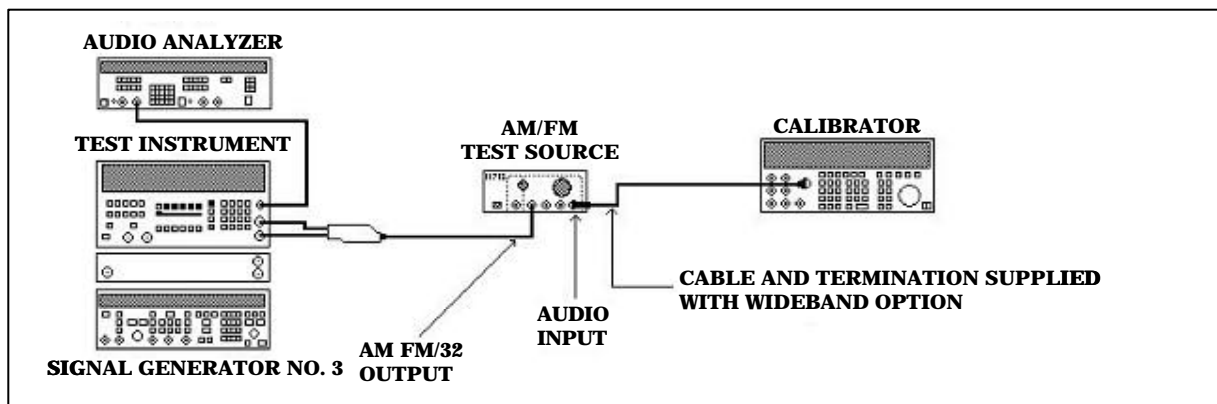

Figure 1. AM distortion

TB 9-6625-2343-50

- (14) Set calibrator for a wideband output of 20 kHz at an amplitude of 215 mV.
- (15) Turn all TI **HP FILTERS** and **LP FILTERS** off.
- (16) Press TI keys as listed in (a) and (b) below:
 - (a) **DETECTOR PEAK+**.
 - (b) **MEASUREMENT AM**.
- (17) Adjust calibrator wideband output for a TI indication of 50 percent AM.
- (18) Set the audio analyzer to measure distortion with 80 kHz low-pass filtering.
- (19) The audio analyzer will indicate within the limits specified in the first row of table 3, if not perform **b** below.
- (20) Repeat technique of (14), (17) and (19) above for remaining frequency and AM percent settings in table 3. The audio analyzer will indicate within the limits specified in table 3, if not perform **b** below.

Table 3. AM Distortion

Calibrator	Test instrument	Audio analyzer
Frequency	AM indication (%)	Indicated limit (%)
20 kHz	50	= 0.3
20 kHz	95	= 0.6
50 Hz	95	= 0.6
50 Hz	50	= 0.3

- (21) Set calibrator for a wideband output of 1 kHz at an amplitude of 383 mV.
- (22) Adjust calibrator output amplitude for a TI indication of 80 percent AM.
- (23) Press calibrator **NEW REF** key.
- (24) Press TI keys as listed in (a) through (c) below:
 - (a) **DETECTOR AVG**.
 - (b) **DISPLAY RATIO**.
 - (c) **DISPLAY LOG/LIN**.
- (25) Change calibrator output frequency to 10 kHz.
- (26) TI will indicate within limits specified in second row of table 4. If not, perform **b** below.
- (27) Repeat technique of (25) above for remaining calibrator frequencies listed in table 4. If TI indications are not within limits specified, perform **b** below.

Table 4. AM Flatness

Calibrator	Test instrument	
	Indication (%)	
	Min	Max
Frequency output		
1 kHz	Ref.	Ref.
10 kHz	99.2	100.8
150 Hz	99.2	100.8
90 Hz	99.2	100.8

- (28) Press TI keys as listed in (a) through (c) below:
 - (a) **DISPLAY RATIO.**
 - (b) **DETECTOR PEAK+.**
 - (c) **DATA 5.1, SPCL.**
- (29) Set calibrator for a wideband output of 10 kHz at an amplitude of 383 mV.
- (30) Adjust calibrator output amplitude for a TI indication of 80 percent multiplied by the reading recorded in step (6) above.

Example: 80 percent AM X 1.004 = 80.32 percent AM
- (31) Press calibrator **NEW REF** key.
- (32) Press TI **80, RATIO** keys.
- (33) Change calibrator output frequency to 50 kHz.
- (34) TI will indicate within limits specified in first row of table 5. If not, perform **b** below.
- (35) Repeat technique of (33) above for remaining calibrator frequencies listed in table 5. If TI indications are not within limits specified, perform **b** below.

Table 5. AM Accuracy

Calibrator Frequency output	Test instrument	
	Indication (%)	
	Min	Max
50 kHz	98.9	101.1
100 kHz	96.9	103.1
50 Hz	98.9	101.1
20 Hz	96.9	103.1

- (36) Press TI **3.1, SPCL** keys.
- (37) Change calibrator output frequency to 50 Hz.
- (38) TI will indicate within limits specified in first row of table 6. If not, perform **b** below.
- (39) Repeat technique of (37) above for remaining calibrator frequencies listed in table 6. If TI indications are not within limits specified, perform **b** below.

Table 6. AM Accuracy (IF 455 kHz)

Calibrator Frequency output	Test instrument	
	Indication (%)	
	Min	Max
50 Hz	97.9	102.1
10 kHz	97.9	102.1
20 Hz	96.9	103.1

- (40) Press TI keys as listed in (a) through (c) below:
 - (a) **DISPLAY RATIO.**
 - (b) **HP FILTER 50 Hz.**
 - (c) **LP FILTER 3 kHz.**

TB 9-6625-2343-50

- (41) Set calibrator for a wideband output of 1 kHz at an amplitude of 241 mV.
- (42) Adjust calibrator output amplitude for a TI indication of 50% AM.
- (43) Press TI **MEASUREMENT FM** key.
- (44) Disconnect calibrator from AM/FM test source **AUDIO INPUT**.
- (45) Record the residual FM displayed on TI.
- (46) Reconnect calibrator to AM/FM test source **AUDIO INPUT**.
- (47) Subtract one-half of the value recorded in step (45) above from the TI displayed value. If the result is not = 20 Hz pk, perform **b** below.
- (48) Press TI **3.0, SPCL** keys.
- (49) Press TI **MEASUREMENT FM** key.
- (50) Disconnect calibrator from AM/FM test source **AUDIO INPUT**.
- (51) Record the residual FM displayed on TI.
- (52) Reconnect calibrator to AM/FM test source **AUDIO INPUT**.
- (53) Subtract one-half of the value recorded in step (51) above from the TI displayed value. If the result is not = 20 Hz pk, perform **b** below.
- (54) Press TI **MEASUREMENT F M** key.
- (55) Disconnect calibrator from AM/FM test source **AUDIO INPUT**.
- (56) Record the residual F M displayed on TI.
- (57) Reconnect calibrator to AM/FM test source **AUDIO INPUT**.
- (58) Subtract one-half of the value recorded in step (56) above from the TI displayed value. If the result is not = 0.030 rad pk, perform **b** below.
- (59) Press TI keys as listed in (a) and (b) below:
 - (a) **BLUE**.
 - (b) **INSTR PRESET**.
- (60) Reduce all outputs to minimum and disconnect equipment setup.

b. Adjustments

- (1) Disconnect equipment setup.
- (2) Press TI keys as listed in (a) through (f) below:
 - (a) **BLUE**.
 - (b) **INSTR PRESET**.
 - (c) **MEASUREMENT AM**.
 - (d) **DETECTOR AVG**.
 - (e) **DISPLAY RATIO**.
 - (f) **LP FILTER >20 kHz**.

- (3) Connect TI sensor module to signal generator No. 1 **RF OUTPUT**.
- (4) Set signal generator No. 1 for an output frequency of 500 MHz at 3 dBm with 30 percent AM at a 1 kHz rate.
- (5) Adjust A2R44 >20kHz LPF GAIN (fig. 2) for a display of 99.95 to 100.05 percent (R).

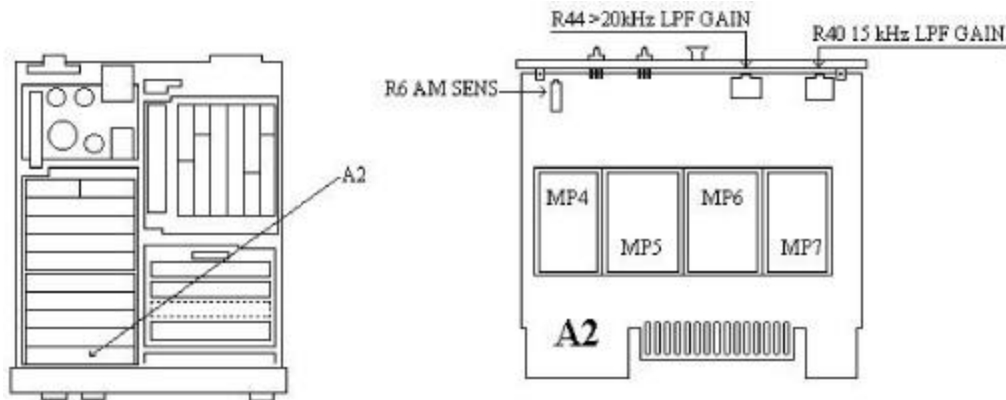

Figure 2. A2 board

- (6) Press TI **LP FILTER 15 kHz** key.
- (7) Adjust A2R40 15kHz LPF GAIN (fig. 2) for a display of 99.95 to 100.05 percent (R).
- (8) Disconnect TI sensor module from signal generator No. 1 **RF OUTPUT**.
- (9) Connect TI sensor module to TI **CALIBRATION RF POWER OUTPUT**.
- (10) Press TI keys as listed in (a) through (d) below:
 - (a) **BLUE**.
 - (b) **INSTR PRESET**.
 - (c) **45.16, SPCL**.
 - (d) **49. (BLUE) 1, SPCL**.
- (11) Adjust A6R65 ALC REF (fig. 3) for a display between 2.0970 and 2.1030 (R).

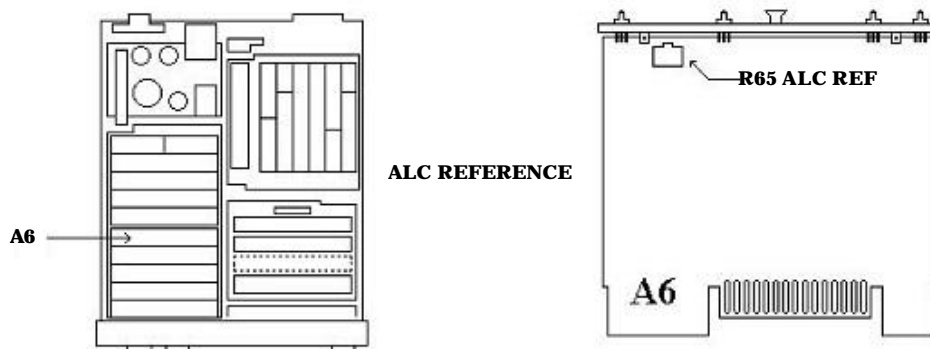

Figure 3. A6 board

TB 9-6625-2343-50

- (12) Disconnect TI sensor module from TI **CALIBRATION RF POWER OUTPUT**.
- (13) Connect TI sensor module to AM/FM test source **FM OUTPUT**.
- (14) Connect calibrator **WIDEBAND** output to AM/FM test source **AUDIO INPUT** using cable and termination supplied with calibrator.
- (15) Set calibrator for a wideband output of 100 kHz at an amplitude of 500 mV.
- (16) Set AM/FM test source **TEST MODE** switch to **FM**.
- (17) Press TI keys as listed in (a) through (c) below:
 - (a) **BLUE**.
 - (b) **INSTR PRESET**.
 - (c) **HP FILTER 50 Hz**.
- (18) Adjust AM/FM test source **CARRIER FREQUENCY TUNE** for a TI indication of approximately 400 MHz.
- (19) Press TI keys as listed in (a) and (b) below:
 - (a) **DATA MHz**.
 - (b) **MEASUREMENT FM**.
- (20) Adjust calibrator level for a TI indication of 400 kHz.
- (21) Switch TI **DETECTOR** between **PEAK+** and **PEAK-** and note the difference between the two indications.



Figure 4. A18 board

- (22) Adjust A18R23 FM DIST 1.5 MHz IF (fig. 4) for equal indications between TI **PEAK+** and **PEAK-** ®.
- (23) Press TI keys as listed in (a) and (b) below:
 - (a) **DATA 3000**.
 - (b) **DATA kHzβ**.

(24) Switch TI **DETECTOR** between **PEAK+** and **PEAK-**. The difference should be <1.6 kHz. If not, adjust A18R23 FM DIST 1.5 MHz IF (fig. 4) to reduce the difference by one-half. Note the indications as PK1+ and PK1-.

(25) Press TI **5kHz** key.

(26) Switch TI **DETECTOR** between **PEAK+** and **PEAK-**. Note the indications as PK2+ and PK2-.

(27) TI is properly adjusted when $[(PK1+ - PK1-) + (PK2+ - PK2-)] < 1.6$ kHz.

(28) Move connection from AM/FM test source **FM OUTPUT** to AM/FM test source **FM/4 OUTPUT**.

(29) Press TI keys as listed in (a) and (b) below:

(a) **LP FILTER 3 kHz.**

(b) **AUTOMATIC OPERATION.**

(30) Set calibrator for a wideband output of 1 kHz at an amplitude of 250 mV.

(31) Adjust calibrator output level for a TI indication of 50 kHz.

(32) Press TI **MEASUREMENT AM** key.

(33) Adjust A18R19 INC AM 1.5 MHz IF (fig. 4) for a minimum display <0.2 percent (R).

(34) Disconnect equipment setup.

(35) Connect TI sensor module to TI **CALIBRATION AM/FM OUTPUT**.

(36) Press TI keys as listed in (a) and (b) below:

(a) **DATA 13.0.**

(b) **DATA SPCL.**

(37) Adjust A50R45 "A" LVL (fig. 5) for a display of 33.330 to 33.336 percent (R).

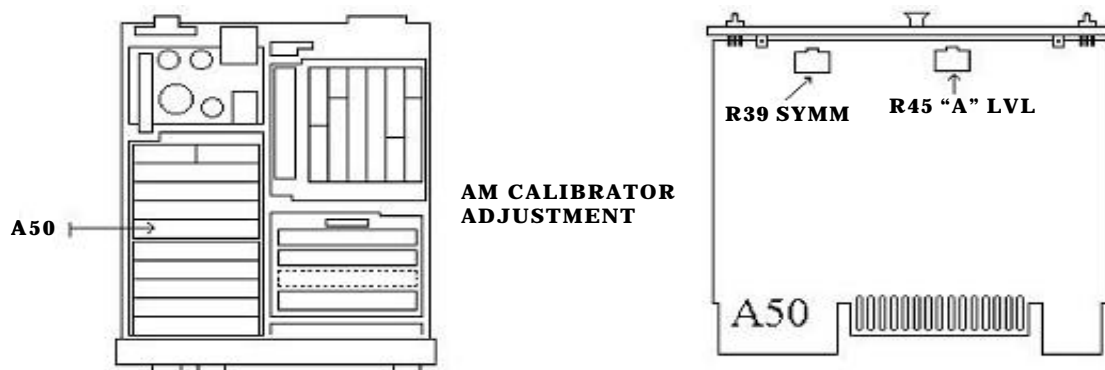

Figure 5. A50 board

TB 9-6625-2343-50

- (38) Press TI keys as listed in (a) and (b) below:
 - (a) **DATA 49.5.**
 - (b) **DATA SP CL.**
- (39) TI display should indicate between 1.8 and 2.2.
- (40) Press TI keys as listed in (a) through (d) below:
 - (a) **DATA 13.2.**
 - (b) **DATA SPCL.**
 - (c) **DATA 5.1.**
 - (d) **DATA SPCL.**
- (41) Alternately switch TI **DETECTOR** between **PEAK+** and **PEAK-**. Note the indications for each setting.
- (42) Adjust A50R39 SYMM (fig. 5) until the indications are the same for both detectors within ± 0.015 percent [®].
- (43) Press TI keys as listed in (a) and (b) below:
 - (a) **MEASUREMENT FM.**
 - (b) **CALIBRATION CALIBRATE.**
- (44) Allow TI to take at least two readings, then adjust A2R6 AM SENS (fig. 2) for a displayed indication of 99.95 percent to 100.05 percent [®].
- (45) Press TI **CALIBRATION CALIBRATE** key.
- (46) Reduce all outputs to minimum and disconnect equipment setup.

9. Frequency Modulation

a. Performance Check

NOTE

In the following procedure, any source can be connected either to a sensor module (as written) or directly to the TI **INPUT 50 ?**.

- (1) Connect AM/FM test source **LOW RESIDUAL OUTPUT** to TI sensor module.
- (2) Set AM/FM test source **TEST MODE** switch to **RESIDUAL FM.**
- (3) Press TI keys as listed in (a) through (f) below:
 - (a) **BLUE.**
 - (b) **INSTR PRESET.**
 - (c) **MEASUREMENT FM.**
 - (d) **HP FILTER 50 Hz.**
 - (e) **LP FILTER 3 kHz.**
 - (f) **DETECTOR AVG.**
- (4) If TI indication is not = 4 Hz, perform **b** below.

- (5) Disconnect TI sensor module from AM/FM test source **LOW RESIDUAL OUTPUT**.
- (6) Connect TI sensor module to TI **CALIBRATION AM/FM OUTPUT**.
- (7) Press TI **CALIBRATION CALIBRATE** key.
- (8) Allow TI to take at least two readings.
- (9) Record TI indication value as 40 kHz ref for future reference.
- (10) If TI indication is not between 99 and 101 percent, perform **b** below.
- (11) Press TI keys as listed in (a) and (b) below:
 - (a) **DATA 2.3**.
 - (b) **SPCL**.
- (12) Allow TI to take at least two readings.
- (13) Record TI indication value as 400 kHz ref for future reference.
- (14) If TI indication is not between 99 and 101 percent, perform **b** below.
- (15) Set AM/FM test source **TEST MODE** switch to **FM**.
- (16) Connect equipment as shown in figure 6 below.

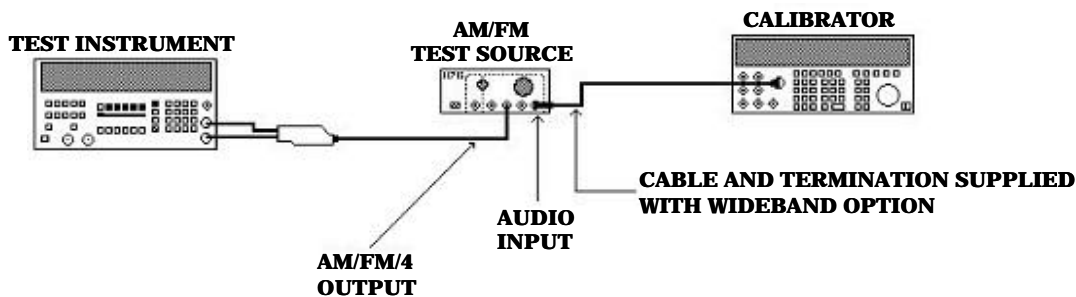

Figure 6. FM Equipment setup

- (17) Set calibrator for a wideband output frequency of 10 kHz at an amplitude of 0.14354V.
- (18) Press TI keys as listed in (a) and (b) below:
 - (a) **MEASUREMENT FREQ.**
 - (b) **TRACK MODE**.
- (19) Adjust AM/FM test source **CARRIER FREQUENCY TUNE** for a TI indication of approximately 100 MHz.
- (20) Press TI keys as listed in (a) through (g) below:
 - (a) **TRACK MODE** (off).
 - (b) **MEASUREMENT FM**.

TB 9-6625-2343-50

- (c) **LP FILTER 15 kHz.**
- (d) **DETECTOR AVG.**
- (e) **DATA 2.0.**
- (f) **DATA SPCL.**

(21) Adjust calibrator output frequency for a TI indication of 20 kHz.

(22) Press TI keys as listed in (a) and (b) below:

- (a) **DISPLAY RATIO.**
- (b) **DISPLAY LIN.**

(23) Move TI sensor module from AM/FM test source **FM/4** to **FM/32** connector without disturbing any of the AM/FM test source controls.

(24) Multiply the indication on TI by the 40 kHz ref value recorded in (9) above. If the result is not between 12.35 and 12.65 percent, perform **b** below.

(25) Move TI sensor module from AM/FM test source **FM/32** to **FM/4** connector.

(26) Press TI keys as listed in (a) and (b) below:

- (a) **DISPLAY RATIO** (off).
- (b) **DETECTOR PEAK+.**

(27) Ensure all TI **HP FILTERS** and **LP FILTERS** are off.

(28) Set calibrator output for a frequency of 100 kHz at an amplitude of 500 mV.

(29) Adjust calibrator output for a TI indication of 100 kHz.

(30) Set audio analyzer to measure distortion and ensure that all audio analyzer filters are off.

(31) If audio analyzer does not indicate = 0.1%, perform **b** below.

(32) Set calibrator output frequency to 10 kHz at an output amplitude of 500 mV.

(33) Adjust calibrator output for a TI indication of 100 kHz multiplied by the 400 kHz ref value recorded in (13) above.

Example: 100 kHz X 1.004= 100.4 kHz

(34) Press calibrator **NEW REF** key.

(35) Change calibrator output frequency to 50 kHz.

(36) TI will indicate within limits specified in first row of table 7. If not, perform **b** below.

(37) Repeat step (35) above for remaining calibrator frequencies listed in table 7. If TI indications are not within limits specified, perform **b** below.

Table 7. 1.5 MHz IF Accuracy

Calibrator frequency output	Test instrument indications (%)	
	Min	Max
50 kHz	98.9	101.1
100 kHz	94.9	105.1
50 Hz	98.9	101.1
20 Hz	94.9	105.1

- (38) Press TI keys as listed in (a) and (b) below:
- (a) **HP FILTER 50 Hz.**
 - (b) **LP FILTER 3 kHz.**
- (39) Set calibrator output frequency to 1 kHz and output amplitude to 250 mV.
- (40) Adjust calibrator amplitude for a TI indication of 50 kHz peak deviation.
- (41) Press TI **MEASUREMENT AM** key.
- (42) Disconnect calibrator from AM/FM test source **AUDIO INPUT**.
- (43) Record the indication displayed on TI as residual AM1.
- (44) Reconnect calibrator to AM/FM test source **AUDIO INPUT**.
- (45) Subtract one half of the residual AM1 indication recorded in (43) above from TI displayed indication. If result is not = 0.2%, perform **b** below.
- (46) Move TI sensor module from AM/FM test source **FM/4** to **FM/32** connector.
- (47) Press TI keys as listed in (a) through (c) below:
- (a) **DATA 3.1.**
 - (b) **DATA SPCL.**
 - (c) **MEASUREMENT FM.**
- (48) Set calibrator output frequency to 1 kHz and output amplitude to 200 mV.
- (49) Adjust calibrator amplitude for a TI indication of 5 kHz peak deviation.
- (50) Press TI **MEASUREMENT AM** key.
- (51) Disconnect calibrator from AM/FM test source **AUDIO INPUT**.
- (52) Record the indication displayed on TI as residual AM2.
- (53) Reconnect calibrator to AM/FM test source **AUDIO INPUT**.
- (54) Subtract one half of the residual AM2 indication recorded in (52) above from TI displayed indication. If result is not = 0.2%, perform **b** below.
- (55) Press TI keys as listed in (a) through (c) below:
- (a) **MEASUREMENT FM.**
 - (b) **HP FILTER** (all off).
 - (c) **LP FILTER >kHz.**

TB 9-6625-2343-50

- (56) Set calibrator output frequency to 1 kHz at an output amplitude of 400 mV.
- (57) Adjust calibrator output for a TI indication of the product of the following: (10 kHz peak deviation multiplied by the 40 kHz ref value recorded in (9) above).
- (58) Press calibrator **NEW REF** key.
- (59) Change calibrator output frequency to 10 kHz.
- (60) If TI does not indicate within limits specified in first row of table 8, perform **b** below.
- (61) Repeat technique of (59) above for remaining calibrator frequency listed in table 8. If TI indications are not within limits specified, perform **b** below.

Table 8. 455 kHz IF Accuracy

Calibrator frequency	Test instrument indications (kHz)	
	Min	Max
output		
10 kHz	9.79	10.21
20 Hz	9.79	10.21

- (62) Change calibrator output frequency to 10 kHz at an amplitude of 400 mV.
- (63) Adjust calibrator output for a TI indication of 10 kHz peak deviation.
- (64) Set audio analyzer for a **DISTORTION** measurement with 30 kHz low pass filter activated.
- (65) If audio analyzer does not indicate = 0.1%, perform **b** below.
- (66) Reduce all outputs to minimum and disconnect equipment setup.

b. Adjustments

- (1) Disconnect equipment setup.
- (2) Connect TI sensor module to signal generator No. 1 **RF OUTPUT**.
- (3) Connect oscilloscope **CH1** to A23TP1 SMPL AMPL (fig 7).

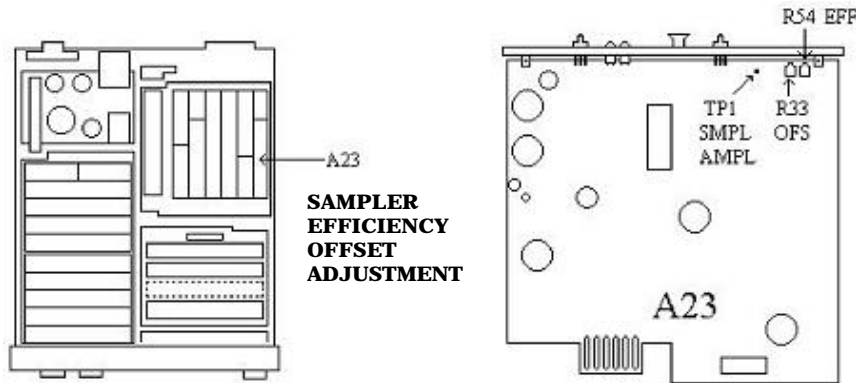

Figure 7. A23 board.

- (4) Set signal generator No. 1 for an output of 18 MHz at a level of 0 dBm.
- (5) Set oscilloscope for the following:
 - (a) **CH1 COUPLING AC.**
 - (b) **CH1 VOLTS/DIV 0.2.**
 - (c) **A SEC/DIV 10 μ s.**
- (6) Press TI keys as listed in (a) through (c) below:
 - (a) **INSTR PRESET.**
 - (b) **DATA 18 MHz.**
 - (c) **TRACK MODE.**
- (7) Fine tune signal generator No. 1 up slowly until a zero beat appears on oscilloscope. Then increase signal generator No. 1 frequency by 1 kHz. Record the oscilloscope peak to peak amplitude as PK#1.
- (8) Increase signal generator No. 1 frequency by 30 kHz.
- (9) Adjust A23R33 OFS (fig. 7) such that when the oscilloscope input coupling is changed from ac to dc the waveform shifts upward 50 mV. Adjust only when the input coupling is set to dc. (R)
- (10) Adjust A23R54 EFF (fig. 7) for an oscilloscope indication of PK No.1 value recorded in (7) above.

NOTE

If A23R54 EFF doesn't have sufficient range, refer to manufacturer's manual, page 5-9.

- (11) Disconnect all external equipment from TI and connect TI sensor module to **TI CALIBRATION AM/FM OUTPUT.**
- (12) Press TI keys as listed in (a) through (d) below:
 - (a) **DATA 12.1.**
 - (b) **DATA SPCL.**
 - (c) **DATA 46.3.**
 - (d) **DATA SPCL.**
- (13) Adjust A51C20 FREQ (fig. 8) for a TI display between 1009000 and 1011000.
(R)

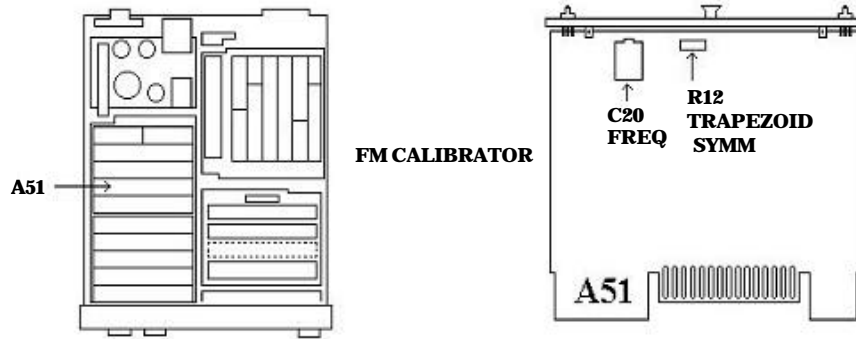

Figure 8. A51 board.

(14) Press TI keys as listed in (a) through (d) below:

- (a) **DATA 12.2.**
- (b) **DATA SPCL.**
- (c) **DATA 5.1.**
- (d) **DATA SPCL.**

(15) Alternately switch TI **DETECTOR** between **PEAK+** and **PEAK-** and note the display for each detector.

(16) Adjust A51R12 TRAPEZOID SYMM (fig. 8) until the readings are the same for both detectors within ± 0.010 kHz. (R)

(17) Press TI keys as listed in (a) and (b) below:

- (a) **MEASUREMENT FM.**
- (b) **CALIBRATION CALIBRATE.**

(18) Allow TI to take at least two readings.

(19) Adjust A4R50 FM SENS (fig. 9) for a displayed indication between 99.95 and 100.05 percent. (R)

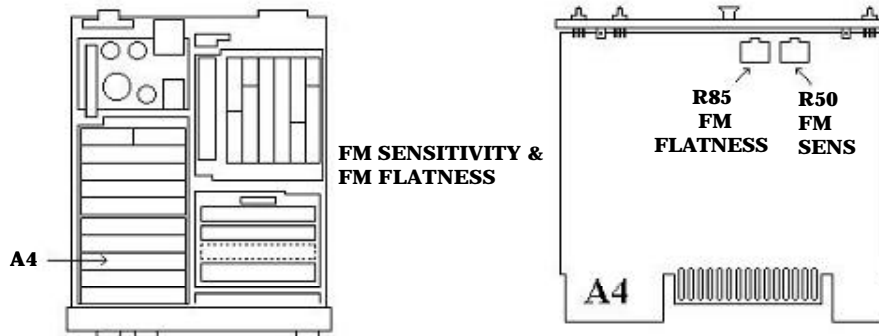

Figure 9. A4 board.

- (20) Press TI **INSTR PRESET** key.
- (21) Connect TI sensor module to AM/FM test source **FM OUTPUT**.
- (22) Connect calibrator wideband **OUTPUT** TO AM/FM test source **AUDIO INPUT**.
- (23) Set calibrator for a wideband output frequency of 1 kHz and an amplitude of 500 mV.
- (24) Set AM/FM test source **TEST MODE** switch to **FM**.
- (25) Adjust AM/FM test source **CARRIER FREQUENCY TUNE** for a TI indication of approximately 400 MHz.
- (26) Press TI keys as listed in (a) through (c) below:
 - (a) **DATA MHz.**
 - (b) **MEASUREMENT FM.**
 - (c) **DETECTOR AVG.**
- (27) Adjust calibrator level for a TI indication of 280 kHz.
- (28) Press calibrator **NEW REF** key.
- (29) Press TI **RATIO** key.
- (30) Change calibrator output frequency to 150 kHz.
- (31) Adjust A4R85 FM FLATNESS (fig. 9) for a display between 99.9 and 100.1 percent. (R)
- (32) Press TI keys as listed in (a) through (c) below:
 - (a) **INSTR PRESET.**
 - (b) **HP FILTER 300 Hz.**
 - (c) **LP FILTER 3 kHz.**
- (33) Set calibrator for a wideband output frequency of 1 kHz at an amplitude of 500 mV.
- (34) Move TI sensor module from AM/FM test source **FM OUTPUT** to **FM/4 OUTPUT**.
- (35) Adjust AM/FM test source **CARRIER FREQUENCY TUNE** for a TI indication of approximately 100 MHz.
- (36) Press TI keys as listed in (a) and (b) below:
 - (a) **DATA MHz.**
 - (b) **MEASUREMENT FM.**
- (37) Adjust calibrator output for a TI indication 100 kHz.
- (38) Press TI **MEASUREMENT F M** key.
- (39) Adjust A3R27 PM SENS (fig 10) for a TI indication of 100 ± 0.2 rad. (R)

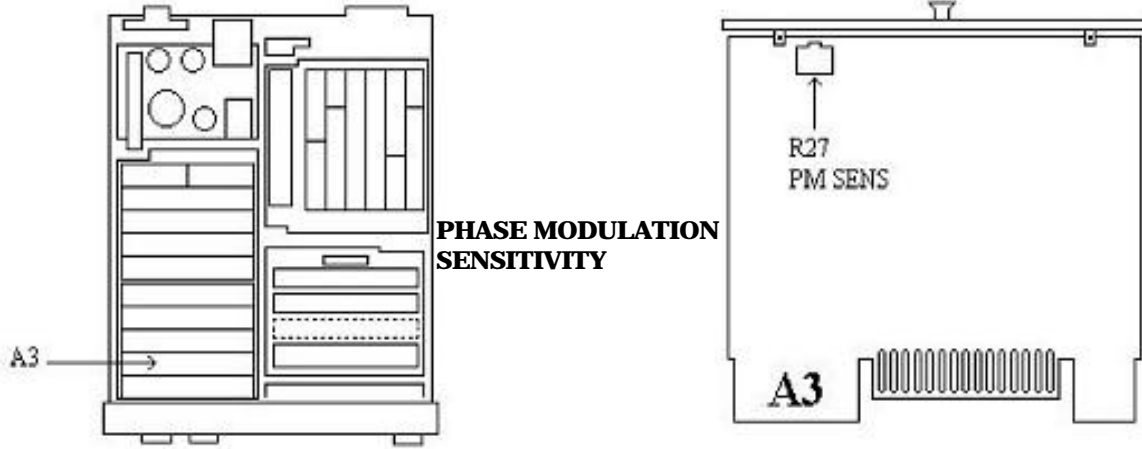

Figure 10 A3 board.

(40) Reduce all outputs to minimum and disconnect equipment setup.

10. Phase Modulation

a. Performance Check

- (1) Press TI **INSTR PRESET** key.
- (2) Set AM/FM test source **TEST MODE** switch to **FM** and connect equipment as shown in figure 11 below.

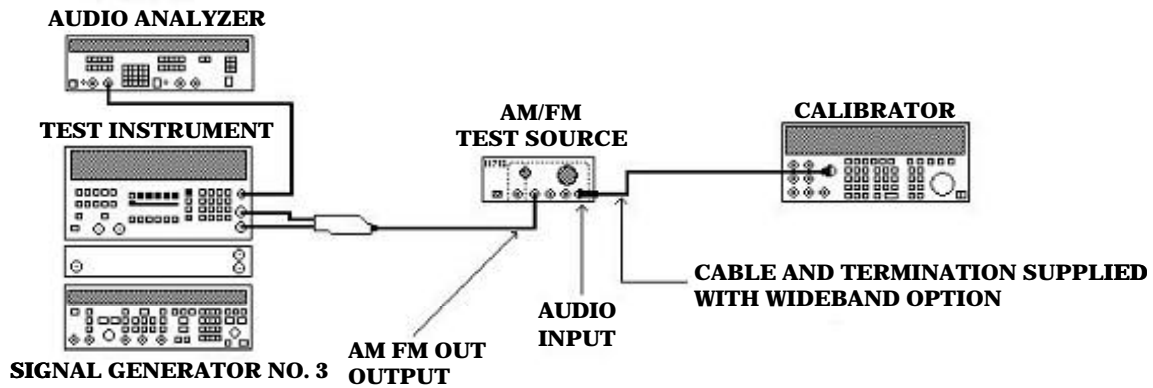

Figure 11. Phase modulation setup.

- (3) Set calibrator for a wideband output frequency of 200 Hz at a level of 89.6 mV.

- (4) Press TI keys as listed in (a) and (b) below:
 - (a) **MEASUREMENT FREQ.**
 - (b) **TRACK MODE.**
- (5) Adjust AM/FM test source **CARRIER FREQUENCY TUNE** for a TI indication of approximately 400 MHz.
- (6) Press TI keys as listed in (a) through (e) below:
 - (a) **TRACK MODE** (off).
 - (b) **MEASUREMENT FM.**
 - (c) **HP FILTER 50 Hz.**
 - (d) **LP FILTER >20 kHz.**
 - (e) **DETECTOR AVG.**
- (7) Adjust calibrator level for a TI indication of 50 kHz.
- (8) Press TI **F M** key.
- (9) If TI indication is not between 242.4 rad and 257.6 rad, perform **b** below.
- (10) Press TI keys as listed in (a) and (b) below:
 - (a) **MEASUREMENT FM.**
 - (b) **HP FILTER 300 Hz.**
- (11) Set calibrator for a wideband output frequency of 1 kHz at a level of 446.3 mV.
- (12) Adjust calibrator level for a TI indication of 250 kHz.
- (13) Press TI **F M** key.
- (14) If TI indication is not within limits specified in the first row of table 9, perform **b** below.
- (15) Repeat technique of (10)(a) and (11) through (13) above for remaining calibrator initial settings and TI FM deviations in table 9. If TI indications are not within limits specified, perform **b** below.

Table 9. Φ Modulation, 250 kHz FM Deviation.

Calibrator initial output		Test Instrument		
		FM deviation indication (kHz)	Φ Modulation indication (rad)	
Frequency	Level (mV)			Min
1 kHz	446.3	250	242.4	257.6
20 kHz	454.9	250	12.0	13.0

- (16) Move TI sensor module from AM/FM test source **FM OUTPUT** to **FM/32 OUTPUT.**
- (17) Set calibrator for a wideband output frequency of 20 kHz at a level of 233.3 mV.
- (18) Press TI keys as listed in (a) and (b) below:
 - (a) **AUTOMATIC OPERATION.**
 - (b) **MEASUREMENT FM.**

TB 9-6625-2343-50

- (19) Adjust calibrator level for a TI indication of 4 kHz.
- (20) Press TI keys as listed in (a) through (c) below:
 - (a) **MEASUREMENT F M.**
 - (b) **AUTOMATIC OPERATION.**
 - (c) **MEASUREMENT F M.**
- (21) If TI indication is not between 0.193 rad and 0.207 rad, perform **b** below.
- (22) Move TI sensor module from AM/FM test source **FM/32 OUTPUT** to **FM/4 OUTPUT**.
- (23) Press TI keys as listed in (a) through (c) below:
 - (a) **DATA 3.1.**
 - (b) **DATA SPCL.**
 - (c) **MEASUREMENT FM.**
- (24) Set calibrator for a wideband output frequency of 10 kHz at a level of 179.4 mV.
- (25) Adjust calibrator level for a TI indication of 25 kHz.
- (26) Press TI **MEASUREMENT F M** key.
- (27) If TI indication is not within limits specified in the first row of table 10, perform **b** below.
- (28) Repeat technique of (23)(c) and (24) through (26) above for remaining calibrator initial settings and TI FM deviations in table 10. If TI indications are not within limits specified in table 10, perform **b** below.

Table 10. F Modulation Accuracy

Calibrator initial output		Test Instrument		
		FM deviation indication (kHz)	F Modulation indications (rad)	
Frequency	Level (mV)			Max
10 kHz	179.4	25	2.39	2.61
10 kHz	18	2.5	0.239	0.261
1 kHz	178.5	25	24.0	26.0
200 Hz	84	5	24.0	26.0

- (29) Move TI sensor module from AM/FM test source **FM/4 OUTPUT** to **FM OUTPUT**.
- (30) Press TI keys as listed in (a) through (e) below:
 - (a) **AUTOMATIC OPERATION.**
 - (b) **MEASUREMENT F M.**
 - (c) **DETECTOR PEAK+.**
 - (d) **HP FILTER 300 Hz.**
 - (e) **LP FILTER 15 kHz.**
- (31) Set audio analyzer for an output of 1 kHz source frequency, 1 mV level step, 600 Ω output impedance, 4.38 V output level, and activate HP filter.

- (32) Disconnect calibrator from AM/FM test source.
- (33) Connect audio analyzer **OUTPUT HIGH** to AM/FM test source **AUDIO INPUT**.
- (34) Adjust audio analyzer source level for a TI indication of 400 rad.
- (35) Enable audio analyzer special function 15, and then activate distortion function.
- (36) If audio analyzer indication is not = 0.1%, perform **b** below.
- (37) Set audio analyzer for an output level of 440 mV and 1 mV level steps.
- (38) Adjust audio analyzer source level for a TI indication of 40 rad.
- (39) Press TI keys as listed in (a) through (c) below:
 - (a) **DATA 3.1**.
 - (b) **DATA SPCL**.
 - (c) **MEASUREMENT F M**.
- (40) Enable audio analyzer special function 15, and then activate distortion function.
- (41) If audio analyzer indication is not = 0.1%, perform **b** below.
- (42) Reduce all outputs to minimum and disconnect equipment setup.

b. Adjustments

- (1) Disconnect equipment setup.
- (2) Connect AM/FM test source **FM/4 OUTPUT** to TI sensor module.
- (3) Connect calibrator **WIDEBAND OUTPUT** to AM/FM test source **AUDIO INPUT**.
- (4) Set calibrator for a wideband output frequency of 1 kHz at a level of 500 mV.
- (5) Press TI keys as listed in (a) through (c) below:
 - (a) **INSTR PRESET**.
 - (b) **HP FILTER 300 Hz**.
 - (c) **LP FILTER 3 kHz**.
- (6) Adjust AM/FM test source **CARRIER FREQUENCY TUNE** control for a TI indication of approximately 100 MHz.
- (7) Press TI keys as listed in (a) and (b) below:
 - (a) **DATA MHz**.
 - (b) **MEASUREMENT FM**.
- (8) Adjust calibrator level for a TI indication of 100 kHz.
- (9) Press TI **F M** key.
- (10) Adjust A3R27 PM SENS (fig. 12) for a TI indication of 100 ± 0.2 rad. (R)

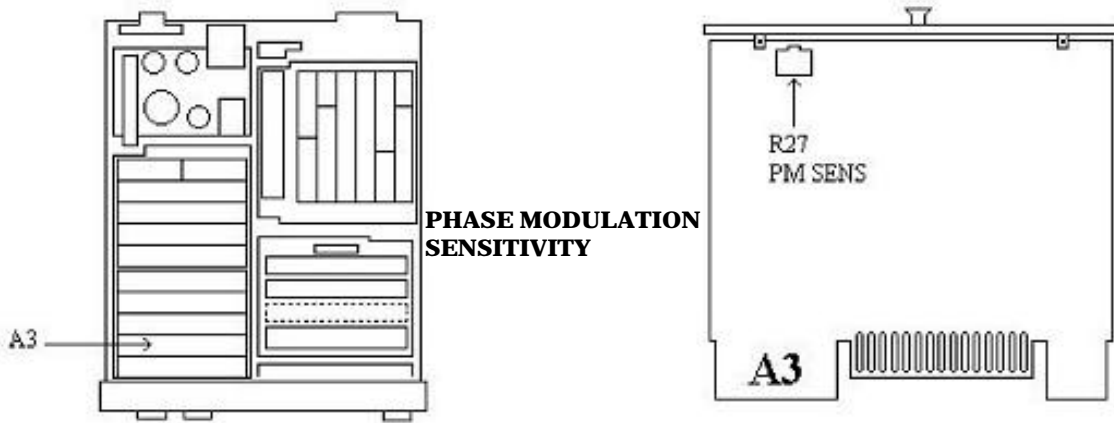

Figure 12. A3 board.

NOTE

If this adjustment is made, repeat FM performance check.

- (11) Reduce all outputs to minimum and disconnect equipment setup.

11. Audio Filters

a. Performance Check

- (1) Press TI **INSTR PRESET** key.
- (2) Set AM/FM test source **TEST MODE** switch to **FM**.
- (3) Connect equipment as shown in figure 13.

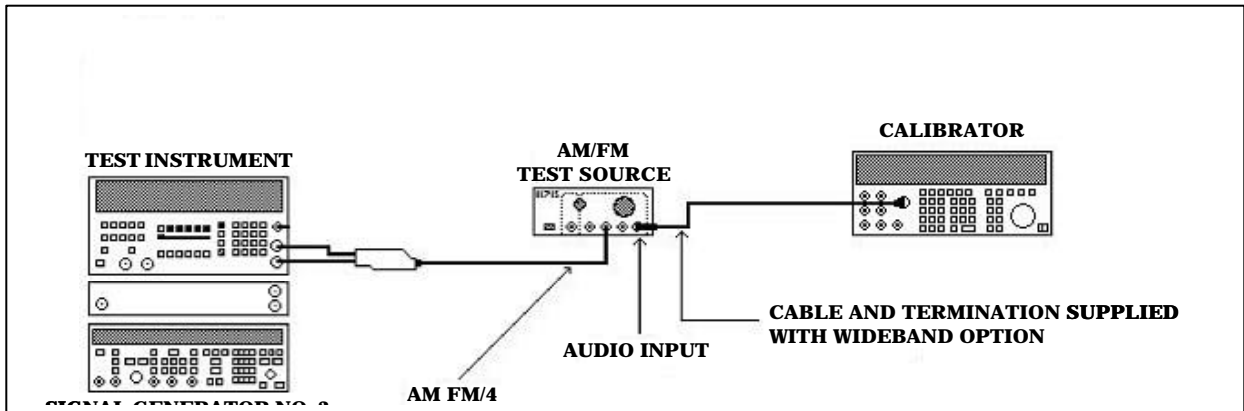

Figure 13. Audio filters setup.

- (4) Set calibrator for a wideband output frequency of 200 Hz at a level of 178.5 mV.

- (5) Press TI keys as listed in (a) and (b) below:
 - (a) **MEASUREMENT FREQ.**
 - (b) **TRACK MODE.**
- (6) Adjust AM/FM test source **CARRIER FREQUENCY TUNE** control for a TI indication of approximately 100 MHz.
- (7) Press TI keys as listed in (a) through (d) below:
 - (a) **TRACK MODE** (off).
 - (b) **DATA MHz.**
 - (c) **MEASUREMENT FM.**
 - (d) **DETECTOR AVG.**
- (8) Adjust calibrator level for a TI indication of 25 kHz.
- (9) Press calibrator **NEW REF** key.
- (10) Press TI keys as listed in (a) through (d) below:
 - (a) **DISPLAY RATIO** (off).
 - (b) **HP FILTERS** (all off).
 - (c) **LP FILTERS** (all off).
 - (d) **DISPLAY RATIO** (on).
 - (e) **HP FILTER 50 Hz** (on).
- (11) TI will indicate within limits specified in first row of table 11.
- (12) Change calibrator output frequency to 2 kHz.
- (13) Repeat technique of steps (10) and (12) above using filters and calibrator output frequencies in table in table 11. TI will indicate within limits specified in table 11.

Table 11. Audio Filters

Calibrator	Test instrument		
	Active filter	Indications (% REL)	
		Min	Max
200 Hz	50 Hz HP	98.99	101.01
2 kHz	50 Hz HP	98.99	101.01
1 kHz	300 Hz HP	98.99	101.01
10 kHz	300 Hz HP	98.99	101.01
1 kHz	3 kHz LP	98.99	101.01
100 Hz	3 kHz LP	98.99	101.01
10 kHz	15 kHz LP	98.99	101.01
1 kHz	15 kHz LP	98.99	101.01
10 kHz	>20 kHz LP	98.99	101.01
1 kHz	>20 kHz LP	98.99	101.01

- (14) Reduce all outputs to minimum and disconnect equipment setup.

b. Adjustments. None

12. Audio Measurements

a. Performance Check

- (1) Press TI keys as listed in (a) through (c) below:
 - (a) **INSTR PRESET.**
 - (b) **DATA 3.0.**
 - (c) **DATA SPCL.**
- (2) Reset calibrator.
- (3) Connect calibrator **WIDEBAND OUT** to TI **MODULATION OUTPUT/AUDIO INPUT** using cable and termination supplied with calibrator.
- (4) Set calibrator for a wideband output frequency of 50 Hz at a level of 3 V.
- (5) Press calibrator **NEW REF** key.
- (6) If TI does not indicate within limits specified in first row of table 12, perform **b** below.
- (7) Repeat technique of step (4) above, changing only the calibrator output frequency to frequencies listed in table 12. If TI does not indicate within limits specified in table 12, perform **b** below.

Table 12. Audio Accuracy 3 Vrms.

Calibrator	Test instrument	
	Indications (V rms)	
	Min	Max
Output frequency		
50 Hz	2.88	3.12
500 Hz	2.88	3.12
5 kHz	2.88	3.12
40 kHz	2.88	3.12

- (8) Change calibrator output to a frequency of 40 kHz at a level of 100 mV.
- (9) Press calibrator **NEW REF** key.
- (10) If TI does not indicate within limits specified in first row of table 13, perform **b** below.
- (11) Repeat technique of step (8) above, changing only the calibrator output frequency to frequencies listed in table 13. If TI does not indicate within limits specified in table 13, perform **b** below.

Table 13. Audio Accuracy 100 mV rms.

Calibrator	Test instrument	
	Indications (mV rms)	
	Min	Max
Output frequency		
40 kHz	96.0	104.0
5 kHz	96.0	104.0
500 Hz	96.0	104.0
50 Hz	96.0	104.0

- (12) Change calibrator output to a frequency of 380 Hz at a level of 100 mV.
- (13) Press TI keys as listed in (a) through (d) below:
 - (a) **MEASUREMENT S** (shift).
 - (b) **AUDIO DISTN.**
 - (c) **BLUE.**
 - (d) **400 Hz DISTN.**
- (14) Slowly step the calibrator output frequency up to 420 Hz in 2 Hz steps while observing the TI distortion indications at each step. If TI indication is not = 0.3%, perform **b** below.
- (15) Change calibrator output level to 3 V.
- (16) Slowly step the calibrator output frequency down to 380 Hz in 2 Hz steps while observing the TI distortion indications at each step. If TI indication is not = 0.3%, perform **b** below.
- (17) Press TI keys as listed in (a) and (b) below:
 - (a) **BLUE.**
 - (b) **1 kHz DISTN.**
- (18) Set calibrator output to a frequency of 950 Hz at a level of 3 V.
- (19) Slowly step the calibrator output frequency up to 1050 Hz in 5 Hz steps while observing the TI distortion indications at each step. If TI indication is not = 0.3%, perform **b** below.
- (20) Change calibrator output level to 100 mV.
- (21) Slowly step the calibrator output frequency down to 950 Hz in 5 Hz steps while observing the TI distortion indications at each step. If TI indication is not = 0.3%, perform **b** below.
- (23) Press audio analyzer **FLOAT** key.
- (22) Connect equipment as shown in figure 14.

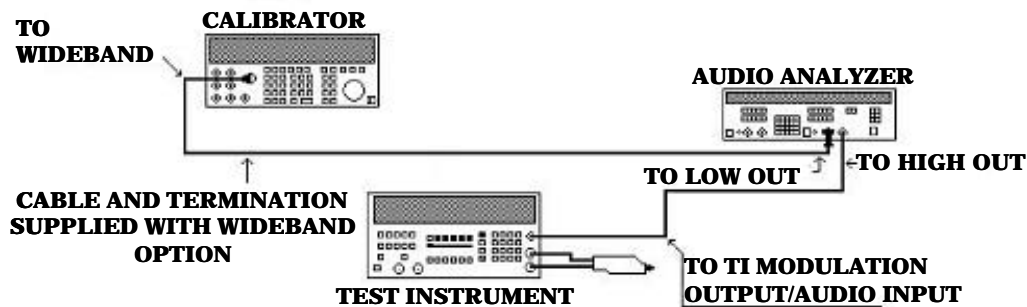

Figure 14. Audio measurement setup.

TB 9-6625-2343-50

- (23) Set audio analyzer source output to 1 kHz at a level of 3 V.
- (24) Set calibrator output for a frequency of 2 kHz at a level of -57 dBm.
- (25) Press TI keys as listed in (a) through (c) below:
 - (a) **DATA 3.0.**
 - (b) **DATA SPCL.**
 - (c) **DISPLAY RATIO.**
- (26) Set audio analyzer source output level to 0 V.
- (27) Increase calibrator output level to 22.53 dBm.
- (28) Adjust calibrator output, if necessary, for a TI indication between 99 and 100%.
- (29) Decrease calibrator output level exactly 40 dBm down.
- (30) Press calibrator **NEW REF** key.
- (31) Set audio analyzer source output level back to 3 V.
- (32) Press TI keys as listed in (a) and (b) below:
 - (a) **MEASUREMENT S** (shift).
 - (b) **AUDIO DISTN.**
- (33) If TI indication is not within limits specified in first row of table 14, perform **b** below.
- (34) Set calibrator output frequency to remaining frequencies in table 14. If TI indications are not within limits specified in table 14, perform **b** below.

Table 14. Distortion Accuracy, 2-5 kHz.

Calibrator	Test instrument	
Output frequency (kHz)	Indications (%)	
	Min	Max
2	0.89	1.12
3	0.89	1.12
4	0.89	1.12
5	0.89	1.12

- (35) Set audio analyzer source output frequency to 400 Hz.
- (36) Press TI keys as listed in (a) and (b) below:
 - (a) **BLUE.**
 - (b) **400 Hz DISTN.**
- (37) Set calibrator output frequency to 800 Hz.
- (38) If TI indication is not within limits specified in first row of table 15, perform **b** below.
- (39) Repeat technique of (37) above for remaining frequencies in table 15. If TI indications are not within limits specified in table 15, perform **b** below.

Table 15. Distortion Accuracy, 800 Hz to 2 kHz.

Calibrator		Test instrument	
Output frequency		Indications (%)	
		Min	Max
800	Hz	0.89	1.12
1200	Hz	0.89	1.12
1600	Hz	0.89	1.12
2	kHz	0.89	1.12

(40) Reduce all outputs to minimum and disconnect calibrator and audio analyzer from TI.

(41) Connect synthesizer/function generator **OUTPUT** to TI **MODULATION OUTPUT/AUDIO INPUT** using a 50 Ω feed through termination.

(42) Press TI keys as listed in (a) and (b) below:

(a) **MEASUREMENT S** (shift).

(b) **AUDIO FREQ.**

(43) Set synthesizer/function generator for a sine wave output of 20 Hz at a level of 3 V.

(44) If TI does not indicate within limits specified in first row of table 16, perform **b** below.

(45) Repeat technique of (43) above for remaining frequencies and levels in table 16. If TI indications are not within limits specified in table 16, perform **b** below.

Table 16. Audio Counter Accuracy.

Synthesizer/function generator		Test instrument	
Output		Indications (Hz)	
Frequency	Level	Min	Max
20 Hz	3.0 V	19.98	20.02
20 Hz	100 mV	19.98	20.02
1 kHz	100 mV	999.97	1000.03
1 kHz	3.0 V	999.97	1000.03
250 kHz	3.0 V	249997	250003
250 kHz	100 mV	249997	250003

(46) Reduce all outputs to minimum and disconnect equipment setup.

b. Adjustments

(1) Reduce all outputs to minimum and disconnect equipment setup.

(2) Press TI **INSTR PRESET**.

(3) Remove any cable from TI **MODULATION OUTPUT/AUDIO INPUT**.

(4) Press TI keys as listed in (a) through (d) below:

(a) **DATA 30.0**.

(b) **DATA SPCL**.

TB 9-6625-2343-50

- (c) **DATA 49.7.**
- (d) **DATA SPCL.**
- (5) Adjust A52R47 RMS OFS (fig. 15) for a TI indication of between -0.0005 and 0.0005 . (R)

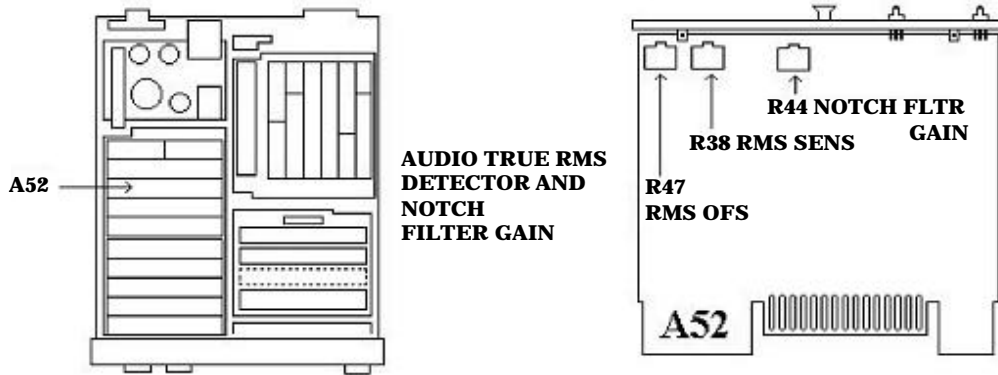

Figure 15. A52 board.

- (6) Press TI keys as listed in (a) and (b) below:
 - (a) **DATA 30.0.**
 - (b) **DATA SPCL.**
- (7) Using a tee connector, connect audio analyzer **OUTPUT HI** to TI **MODULATION OUTPUT /AUDIO INPUT** and digital multimeter **INPUT**.
- (8) Set digital multimeter to read ac volts.
- (9) Set audio analyzer for an output frequency of 2 kHz at a level of 3.9 Volts.
- (10) Adjust A52R38 RMS SENS (fig.15) for a TI display equal to the indication of the digital multimeter to the third decimal place. (R)
- (11) Change audio analyzer output level to 100 mV.
- (12) Press TI keys as listed in (a) and (b) below:
 - (a) **MEASUREMENT S** (shift).
 - (b) **AUDIO DISTN.**
- (13) Adjust A52R44 NOTCH FLTR GAIN (fig. 15) for a TI display between 99.9 and 100.1%. (R)
- (14) Change audio analyzer output frequency to 800 Hz.
- (15) Press TI keys as listed in (a) and (b) below:
 - (a) **BLUE.**
 - (b) **400 Hz DISTN.**

- (16) TI indication should be greater than 98%.
- (17) Reduce all outputs to minimum and disconnect equipment setup.

13. Power Reference

a. Performance Check

NOTE

The ARGO 1210SA measuring system must be warmed up for at least 1 hour and connected in standard configuration prior to taking measurements.

- (1) Press measuring system digital meter keys as listed in (a) through (g) below:
 - (a) **DCV.**
 - (b) **RANGE, AUTO.**
 - (c) **NPLC, 1.**
 - (d) **DIGITS DISP, 6, ENT.**
 - (e) **NRDGS, 1.**
 - (f) **TRIGGER AUTO.**
 - (g) **TERM, 0.**
- (2) Connect sensor cable supplied with measuring system to thermistor mount.
- (3) Connect thermistor mount to TI **CALIBRATION RF POWER OUTPUT.**
- (4) Press TI keys as listed in (a) and (b) below:
 - (a) **DATA 45.0.**
 - (b) **DATA SPCL.**
- (5) Record indication displayed on digital meter as V off.
- (6) Press TI keys as listed in (a) and (b) below:
 - (a) **DATA 45.16.**
 - (b) **DATA SPCL.**
- (7) Record indication displayed on digital meter as V on.
- (8) Record thermistor mount correction factor for 50 MHz as C.
- (9) Using the formula below, calculate TI ref power. If calculated power is not between 0.998 and 1.012, perform **b** below.

$$5 \times ((V \text{ off}^2 - V \text{ on}^2) \div C) = \text{Ref power}$$

- (10) Disconnect equipment setup.

b. Adjustments

- (1) Disconnect equipment setup.
- (2) Connect TI **CALIBRATION RF POWER OUTPUT** to TI sensor module.

TB 9-6625-2343-50

(3) Press TI keys as listed in (a) through (e) below:

- (a) **BLUE.**
- (b) **INSTR PRESET.**
- (c) **DATA 45.16.**
- (d) **DATA SPCL.**
- (e) **TRACK MODE.**

(4) If TI frequency indication is not between 49.5 and 50.5 MHz remove the thumb screw retaining the A32 oscillator and slide the assembly out. Adjust A32L1 for 50 MHz \pm 0.5 MHz.

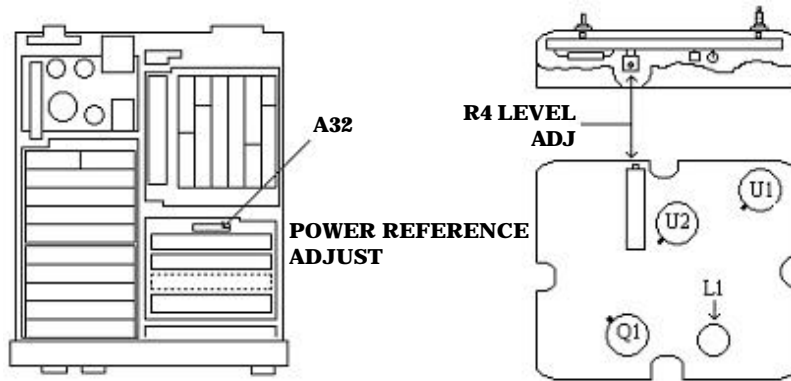

Figure 16. A32 board.

(5) Reinstall A32 assembly.

NOTE

The ARGO 1210SA measuring system must be warmed up for at least 1 hour and connected in standard configuration prior to taking measurements.

(6) Press measuring system digital meter keys as listed in (a) through (g) below:

- (a) **DCV.**
- (b) **RANGE, AUTO.**
- (c) **NPLC, 1.**
- (d) **DIGITS DISP, 6, ENT.**
- (e) **NRDGS, 1.**
- (f) **TRIGGER AUTO.**
- (g) **TERM, 0.**

(7) Connect sensor cable supplied with measuring system to thermistor mount.

(8) Connect thermistor mount to TI **CALIBRATION RF POWER OUTPUT.**

(9) Press TI keys as listed in (a) and (b) below:

- (a) **DATA 45.16.**
- (b) **DATA SPCL.**

(10) Using the V off value recorded in **13a** (5) above and C value from **13a** (8) above, perform the adjustment calculation using the formula below.

$$\text{Adjustment value} = v ((V_{\text{off}}^2 - 200/1000) \div C)$$

(11) Adjust A32R4 LEVEL ADJ (fig 16) to adjustment value calculated in (10) above. (R)

(12) Disconnect equipment setup.

14. Power Meter

a. Performance Check

(1) Press TI keys as listed in (a) and (b) below:

- (a) **BLUE.**
- (b) **INSTR PRESET.**

(2) Connect range calibrator **POWER METER** connector to TI **SENSOR** input.

(3) Set range calibrator switches as listed in (a) through (c) below:

- (a) **FUNCTION STANDBY.**
- (b) **POLARITY NORMAL.**
- (c) **RANGE 1 m W.**

(4) Press TI keys as listed in (a) through (d) below:

- (a) **RF POWER.**
- (b) **ZERO** (wait for the instrument to zero.)
- © **DATA 10.1.**
- (d) **DATA SPCL.**

(5) If TI indication is not within limits specified in first row of table 17, perform **b** below.

(6) Repeat (4) above using remaining TI special functions in table 17. If TI indication is not within limits specified in table 17, perform **b** below.

Table 17. Zero Accuracy

Test instrument	
Special function	Indication limit
10.1	= 0.01 μW
10.2	= 0.1 μW
10.3	= 1 μW
10.4	= 0.01 mW
10.5	= 0.1 mW

TB 9-6625-2343-50

- (7) Set range calibrator to calibrate.
- (8) Press TI keys as listed in (a) through (g) below:
 - (a) **DATA 10.0.**
 - (b) **DATA SPCL.**
 - (c) **CALIBRATION CALIBRATE.**
 - (d) **BLUE.**
 - (e) **CALIBRATION CALIBRATE.**
 - (f) **DATA 10.1.**
 - (g) **DATA SPCL.**
- (9) Set range calibrator to 10 μ W range.
- (10) If TI does not indicate within limits specified in first row of table 18, perform **b** below.
- (11) Repeat technique of (8)(f), (g) and (9) for remaining range calibrator ranges and TI special functions in table 18. If TI indication is not within limits specified in table 18, perform **b** below.

Table 18. Range to Range Accuracy

Range calibrator	Test instrument			
	Special function	Indications		
		Min	Max	
10 μ W	10.1	9.90 μ W	10.10 μ W	
100 μ W	10.2	99.4 μ W	100.6 μ W	
10 mW	10.4	9.94 mW	10.06 mW	
100 mW	10.5	99.0 mW	101.0 mW	

- (12) Set range calibrator to 1 mW range.
- (13) Press TI keys as listed in (a) and (b) below:
 - (a) **DATA 10.4.**
 - (b) **DATA SPCL.**
- (14) Set range calibrator to 100 μ W range.
- (15) If TI does not indicate between 0.099 μ W and 0.101 μ W, perform **b** below.
- (16) Press TI keys as listed in (a) and (b) below:
 - (a) **BLUE.**
 - (b) **INSTR PRESET.**
- (17) Reduce all outputs to minimum and disconnect equipment setup.

b. Adjustments

- (1) Reduce all outputs to minimum and disconnect equipment setup.
- (2) Connect range calibrator **POWER METER** connector to TI **SENSOR** input.
- (3) Set range calibrator to calibrate 1 mW range and normal polarity.

- (4) Press TI **RF POWER** key.
- (5) Adjust A53R40 FREQ (fig. 17) for a maximum indication on TI display.

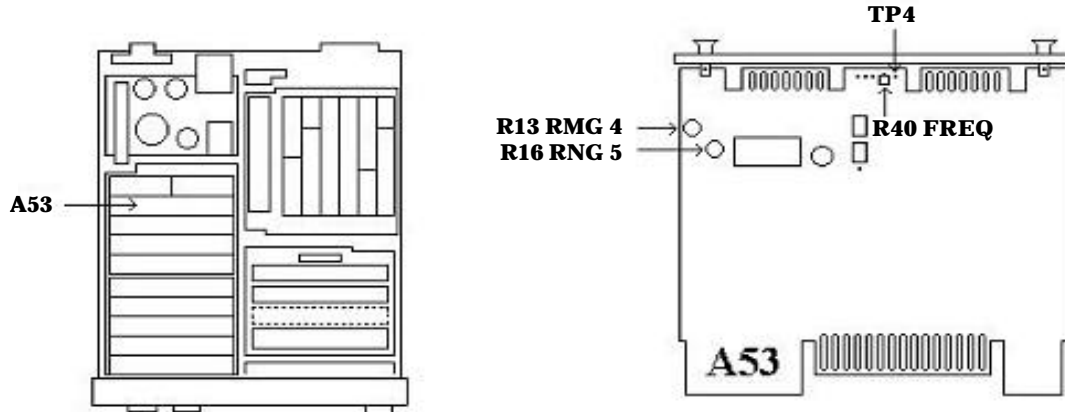

Figure 17. A53 board.

- (6) Press TI keys as listed in (a) and (b) below:
 - (a) **BLUE**.
 - (b) **AUDIO FREQ**.
- (7) Connect TI **MODULATION OUTPUT/AUDIO INPUT** to A53TP4 (fig. 17).
- (8) TI indication should be between 204 and 236 Hz.
- (9) Disconnect A53TP4 (fig. 17) from TI **MODULATION OUTPUT/AUDIO INPUT**.
- (10) Set range calibrator to standby.
- (11) Press TI keys as listed in (a) and (b) below:
 - (a) **RF POWER**.
 - (b) **ZERO**. (wait for the instrument to zero.)
- (12) Set range calibrator to calibrate.
- (13) Press TI keys as listed in (a) through (e) below:
 - (a) **CALIBRATION CALIBRATE**.
 - (b) **BLUE**.
 - (c) **CALIBRATION CALIBRATE**.
 - (d) **DATA 10.4**.
 - (e) **DATA SPCL**.
- (14) Set range calibrator to 10 mW range.
- (15) Turn TI off, remove covers and extend A53 board.

TB 9-6625-2343-50

- (16) Connect extender cable to RF power assembly and connect range calibrator to sensor connector on extender cable.
- (17) Set range calibrator to standby.
- (18) Press TI **ZERO** key.
- (19) Wait for TI to zero.
- (20) Press TI keys as listed in (a) and (b) below:
 - (a) **DATA 10.4.**
 - (b) **DATA SPCL.**
- (21) Set range calibrator to calibrate.
- (22) Press TI keys as listed in (a) through (e) below:
 - (a) **CALIBRATION CALIBRATE.**
 - (b) **BLUE.**
 - (c) **CALIBRATION CALIBRATE.**
 - (d) **DATA 10.4.**
 - (e) **DATA SPCL.**
- (23) Adjust A53R13 RNG 4 (fig. 17) for a TI indication of 10.00 mW.
- (24) Press TI keys as listed in (a) and (b) below:
 - (a) **DATA 10.5.**
 - (b) **DATA SPCL.**
- (25) Set range calibrator to 100 mW range.
- (26) Adjust A53R16 RNG 5 (fig. 17) for a TI indication of 100.0 mW.
- (27) Press TI keys as listed in (a) and (b) below:
 - (a) **BLUE.**
 - (b) **INSTR PRESET.**
- (28) Reduce all outputs to minimum and disconnect equipment setup, reinstall A53 board and repeat performance check.

15. SWR Test

a. Performance Check

- (1) Connect signal generator No.1 **RF OUTPUT** to SWR Bridge **RF INPUT** through a 6 dB fixed attenuator.
- (2) Connect SWR Bridge **REFLECTED RF OUTPUT** to spectrum analyzer **INPUT 50 ? .**
- (3) Press TI **RF POWER** key.
- (4) Set the spectrum analyzer for a start frequency of 3 MHz, stop frequency of 1 GHz and video bandwidth of 30 kHz.

- (5) Set signal generator No.1 for a frequency output of 500 MHz at a level of 3 dBm.
- (6) Set spectrum analyzer for peak search.
- (7) Set spectrum analyzer reference level to marker reference value.
- (8) Set spectrum analyzer for peak search.
- (9) Activate spectrum analyzer delta marker.
- (10) Connect TI sensor to SWR Bridge **DEVICE UNDER TEST** connector.

NOTE

In the tests that follow, ignore error messages displayed by the measuring receiver.

- (11) Set spectrum analyzer sweep time to 50 ms, clear/write trace A, and set trace A to maximum hold.
- (12) Set signal generator No.1 for a single sweep of 100 sec with a start frequency of 2.5 MHz and a stop frequency of 1.3 GHz.
- (13) When sweep is complete, set spectrum analyzer for a marker peak search. Marker amplitude displayed on spectrum analyzer will be $=-23.0$ dB.
- (14) Press TI keys as listed in (a) through (f) below:
 - (a) **MEASUREMENT S** (shift).
 - (b) **TUNED RF LEVEL**.
 - (c) **DATA 1.6**.
 - (d) **DATA SPCL**.
 - (e) **DATA 4.6**.
 - (f) **DATA SPCL**.
- (15) Set spectrum analyzer for clear/write trace A, and set trace A to maximum hold.
- (16) Set signal generator No.1 for a single sweep of 100 sec with a start frequency of 2.5 MHz and a stop frequency of 1.3 GHz.
- (17) When sweep is complete, set spectrum analyzer for a marker peak search. Marker amplitude displayed on spectrum analyzer will be within limits specified in first row of table 19.
- (18) Repeat technique of (14) (e), (f), and (15) through (17) above for remaining TI special function setting in table 19. Marker amplitude displayed on spectrum analyzer will be within limits specified in table 19.

Table 19. Ext Sensor Ranges 1 & 2.

Test instrument	Spectrum analyzer
Special function	Marker amplitude Displayed limit (dB)
1.6	$=-17$
1.2	$=-17$

TB 9-6625-2343-50

- (19) Press spectrum analyzer **INSTRUMENT STATE PRESET** key.
- (20) Set the spectrum analyzer for a start frequency of 3 MHz, stop frequency of 1 GHz and video bandwidth of 30 kHz.
- (21) Disconnect TI sensor module from SWR Bridge **DEVICE UNDER TEST** connector.
- (22) Set signal generator No.1 for a frequency output of 500 MHz at a level of -27 dBm.
- (23) Set spectrum analyzer for peak search.
- (24) Set spectrum analyzer reference level to marker reference value.
- (25) Set spectrum analyzer for peak search.
- (26) Activate spectrum analyzer delta marker.
- (27) Connect TI sensor to SWR Bridge **DEVICE UNDER TEST** connector.
- (28) Press TI keys as listed in (a) and (b) below:
 - (a) **DATA 1.7.**
 - (b) **DATA SPCL.**
- (29) Set spectrum analyzer sweep time to 50 ms, clear/write trace A, and set trace A to maximum hold.
- (30) Set signal generator for a single sweep of 100 sec with a start frequency of 2.5 MHz and a stop frequency of 1.3 GHz.
- (31) When sweep is complete, set spectrum analyzer for a marker peak search. Marker amplitude displayed on spectrum analyzer will be within limits specified in first row of table 20.
- (32) Repeat technique of (28) through (31) above for remaining TI special function setting in table 20. Marker amplitude displayed on spectrum analyzer will be within limits specified in table 20.

Table 20. Ext Sensor Range3 and 14 dB Gain.

Test instrument	Spectrum analyzer
Special functions	Marker amplitude Displayed limit (dB)
1.7	$--14$
1.8	$--17$

- (33) Disconnect TI sensor module from SWR Bridge **DEVICE UNDER TEST** connector.
- (34) Connect TI **INPUT 50?** connector directly to SWR Bridge **DEVICE UNDER TEST** connector.
- (35) Press TI keys as listed in (a) and (b) below:
 - (a) **DATA 1.7.**
 - (b) **DATA SPCL.**

- (36) Set spectrum analyzer sweep time to 50 ms, clear/write trace A, and set trace A to maximum hold.
- (37) Set signal generator for a single sweep of 100 sec with a start frequency of 2.5 MHz and a stop frequency of 1.3 GHz.
- (38) When sweep is complete, set spectrum analyzer for a marker peak search. Marker amplitude displayed on spectrum analyzer will be $=-16.0$ dB.
- (39) Press spectrum analyzer **INSTRUMENT STATE PRESET** key.
- (40) Set the spectrum analyzer for a start frequency of 3 MHz, stop frequency of 1 GHz and video bandwidth of 30 kHz.
- (41) Disconnect TI **INPUT 50?** from SWR Bridge **DEVICE UNDER TEST** connector.
- (42) Set signal generator No.1 for a frequency output of 500 MHz at a level of 3 dBm.
- (43) Set spectrum analyzer for peak search.
- (44) Set spectrum analyzer reference level to marker reference value.
- (45) Set spectrum analyzer for peak search.
- (46) Activate spectrum analyzer delta marker.
- (47) Connect TI **INPUT 50?** directly to SWR Bridge **DEVICE UNDER TEST** connector.
- (48) Press TI keys as listed in (a) and (b) below:
 - (a) **DATA 1.2.**
 - (b) **DATA SPCL.**
- (49) Set spectrum analyzer sweep time to 50 ms, clear/write trace A, and set trace A to maximum hold.
- (50) Set signal generator for a single sweep of 100 sec with a start frequency of 2.5 MHz and a stop frequency of 1.3 GHz.
- (51) When sweep is complete, set spectrum analyzer for a marker peak search. Marker amplitude displayed on spectrum analyzer will be within limits specified in first row of table 21.
- (52) Repeat technique of (41) through (44) above for remaining TI special function setting in table 21. Marker amplitude displayed on spectrum analyzer will be within limits specified in table 21.

Table 21. TI Input Ranges 1 & 2.

Test instrument	Spectrum analyzer
Special function	Marker amplitude displayed limit (dB)
1.2	$= -22$
1.6	$= -22$

TB 9-6625-2343-50

(53) Reduce all outputs to minimum and disconnect equipment setup.

b. Adjustments. None

16. Tuned Level RF

a. Performance Check

NOTE

In the following steps, ignore the RECAL and UNCAL annunciators and error messages.

(1) Connect calibrator **WIDEBAND** output to piston attenuator input (do not use wideband 50? load) and connect piston attenuator output to TI **INPUT 50?** (do not use sensor module).

(2) Set piston attenuator to 20 dB.

(3) Set calibrator for a wideband output frequency of 30 MHz at a level of 22.461 dBm.

(4) Press TI keys as listed in (a) through (l) below:

(a) **BLUE.**

(b) **INSTR PRESET.**

(c) **MEASUREMENT S** (shift).

(d) **TUNED RF LEVEL.**

(e) **DATA 4.6.**

(f) **SPCL.**

(g) **DATA 1.2.**

(h) **DATA SPCL.**

(i) **DATA 9.3.**

(j) **DATA SPCL.**

(k) **DATA 49., MEASUREMENT S** (shift), **1.**

(l) **DATA SPCL.**

(5) Adjust calibrator output amplitude for a TI indication of 3.0 VDC.

(6) Press TI keys as listed in (a) through (d) below:

(a) **DATA CLEAR.**

(b) **BLUE.**

(c) **SET REF.**

(d) **DISPLAY LOG/LIN.**

(7) If TI indication is not 0.00 dBm, press TI **BLUE** key and **SET REF** key until it is.

(8) Set piston attenuator to 30 dB.

(9) TI will indicate within limits specified in table 22.

NOTE

TRV is the Test Report Value for the piston attenuator value selected.

Table 22. IF Average Detector Linearity

Piston attenuator setting (dB)	Test instrument	
	Min Variation (dB)	Max variation (dB)
30	TRV -0.04	TRV +0.04

- (10) Set piston attenuator to 20 dB.
- (11) Press TI keys as listed in (a) through (f) below:
 - (a) **DATA 4.2.**
 - (b) **DATA SPCL.**
 - (c) **DATA 9.1.**
 - (d) **DATA SPCL.**
 - (e) **DATA 50.6.**
 - (f) **DATA SPCL.**
- (12) Adjust calibrator output amplitude for a TI indication of 3.0 VDC.
- (13) Press TI keys as listed in (a) through (d) below:
 - (a) **DATA CLEAR.**
 - (b) **BLUE.**
 - (c) **SET REF.**
 - (d) **DISPLAY LOG/LIN.**
- (14) If TI indication is not 0.00 dBm, press TI **BLUE** key and **SET REF** key until it is.
- (15) Set piston attenuator to 30 dB.
- (16) TI will indicate within limits specified in table 23.

Table 23. IF Synchronous Detector Linearity

Piston attenuator Setting (dB)	Test instrument	
	Min variation (dB)	Max variation (dB)
30	TRV -0.02	TRV +0.02

- (17) Press TI keys as listed in (a) and (b) below:
 - (a) **DATA 9.2.**
 - (b) **DATA SPCL.**
- (18) TI will indicate within limits specified in table 24.
- (19) Repeat technique of (15), (17) and (18) for piston attenuator settings and TI special functions in table 24 below. TI will indicate within calculated limits.

Table 24. IF Range to Range Linearity

Piston attenuator setting (dB)	Test Instrument		
	Special function	Min variation (dB)	Max variation (dB)
30	9.2	TRV -0.02	TRV +0.02
40	9.3	TRV -0.04	TRV +0.04
50	9.4	TRV -0.06	TRV +0.06
60	9.5	TRV -0.08	TRV +0.08
70	9.6	TRV -0.13	TRV +0.13
80	9.7	TRV -0.18	TRV +0.18

- (20) Press TI keys as listed in (a) and (b) below:
 - (a) **BLUE.**
 - (b) **INSTR PRESET.**
- (21) Reduce all outputs and disconnect equipment setup.
- (22) Connect signal generator No.1 **RF OUTPUT** to **TI INPUT 50?** .
- (23) Set signal generator No.1 for an output frequency of 30 MHz, 1 kHz frequency increment steps and an output level of -10 dBm.
- (24) Press TI keys as listed in (a) through (j) below:
 - (a) **MEASUREMENT S** (shift).
 - (b) **TUNED RF LEVEL.**
 - (c) **DATA 4.2.**
 - (d) **DATA SPCL.**
 - (e) **DATA 9.2.**
 - (f) **DATA SPCL.**
 - (g) **DATA CLEAR.**
 - (h) **BLUE.**
 - (i) **SET REF.**
 - (j) **DISPLAY LOG/LIN.**
- (25) If TI indication is not 0.00 dBm, press TI **BLUE** key and **SET REF** key until it is.
- (26) Step signal generator No.1 output frequency down by 1 kHz. TI will display within limits specified in first row of table 25.
- (27) Repeat technique of (26) above for frequency steps listed in table 25 below. TI will display within limits specified in first row of table 25.

Table 25. Negative Frequency Drift Error

Signal generator No.1 output frequency (MHz)	Test instrument	
	Indications (dB)	
	Min	Max
29.999	-0.05	0.05
29.998	-0.10	0.10
29.997	-0.15	0.15
29.996	-0.20	0.20
29.995	-0.25	0.25

(28) Set signal generator No.1 for output frequency to 30 MHz.

(29) Step signal generator No.1 output frequency up by 1 kHz. TI will display within limits specified in first row of table 26.

(30) Repeat technique of (29) above for frequency steps listed in table 26 below. TI will display within limits specified in first row of table 26.

Table 26. Positive Frequency Drift Error

Signal generator No.1 output frequency (MHz)	Test instrument	
	Indications (dB)	
	Min	Max
30.001	-0.05	0.05
30.002	-0.10	0.10
30.003	-0.15	0.15
30.004	-0.20	0.20
30.005	-0.25	0.25

(34) Reduce all outputs to minimum and disconnect equipment setup.

b. Adjustments. None

17. High Select Filters

a. Performance Check

- (1) Press TI keys as listed in (a) and (b) below:
 - (a) **BLUE.**
 - (b) **INSTR PRESET.**
- (2) Connect signal generator No.1 **RF OUTPUT** to TI sensor module.
- (3) Set signal generator No.1 for an output frequency of 455 kHz at an output level of 3 dBm.
- (4) Press TI keys as listed in (a) through (h) below:
 - (a) **DATA 100.**
 - (b) **DATA MHz.**
 - (c) **DATA 24.0.**
 - (d) **DATA SPCL.**
 - (e) **DATA 3.1.**

TB 9-6625-2343-50

- (f) **DATA SPCL.**
- (g) **DATA 24.1.**
- (h) **DATA SPCL.**

(5) Slowly tune the frequency of signal generator No.1 up and down until the peak reading is found.

(6) Press TI keys as listed in (a) through (d) below:

- (a) **DATA 24.1.**
- (b) **DATA SPCL.**
- (c) **DATA 24.2.**
- (d) **DATA SPCL.**

(7) Tune signal generator No.1 down until the first minimum is found. TI indication will be between -2 dB and 0 dB.

(8) Tune signal generator No.1 down until TI indicates -6.00 dB.

(9) Record signal generator No.1 frequency as Freq. #1.

(10) Decrease signal generator No.1 frequency by 1.6 kHz.

(11) TI display will be $=-30$ dB.

(12) Decrease signal generator No.1 frequency by 3 kHz.

(13) TI display will be $=-80$ dB.

(14) Tune signal generator No.1 up until TI indicates 0 dB, and then continue on until TI indicates -6.00 dB.

(15) Record signal generator No.1 frequency as Freq. #2.

(16) Subtract Freq. #1 from Freq. #2. The difference should be between 12.4 and 16.9 kHz.

(17) Increase signal generator No.1 frequency 18.5 kHz above frequency recorded as Freq. #1.

(18) TI display will be $=-30$ dB.

(19) Increase signal generator No.1 frequency by 3 kHz.

(20) TI display will be $=-80$ dB.

(21) Connect equipment as shown in figure 18 below.

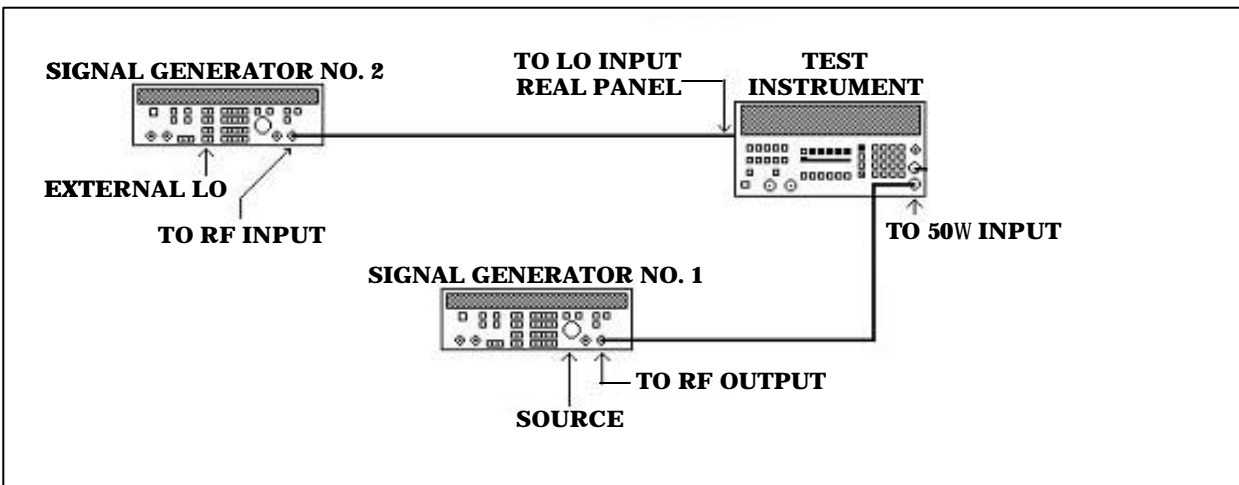

Figure 18. High select filters – equipment connection.

- (22) Set signal generator No.1 for a frequency output of 800 MHz at a level of 0 dB.
- (23) Set signal generator No.2 for a frequency output of 800.455 MHz at a level of 0 dB.
- (24) Press TI keys as listed in (a) through (l) below:
- (a) **DATA 41.0.**
 - (b) **DATA SPCL.**
 - (c) **DATA 1200.**
 - (d) **DATA MHz.**
 - (e) **DATA 23.1.**
 - (f) **DATA SPCL.**
 - (g) **DATA 24.0.**
 - (h) **DATA SPCL.**
 - (i) **DATA 24.5.**
 - (j) **DATA SPCL.**
 - (k) **DATA 24.6.**
 - (l) **DATA SPCL.**
- (25) Increase signal generator No.2 frequency to 800.465 MHz.
- (26) Increase signal generator No.1 frequency to 800.010 MHz and change output level to -75 dBm.
- (27) TI indication will be within limits specified in first row of table 27.
- (28) Repeat technique of (26) above changing output to levels listed in table 27. TI will indicate within limits specified in table 27.

Table 27. Level Ratio.

Signal generator No.1 output level (dBm)	Test instrument	
	Indication limits (dB)	
	Min	Max
-75	-76.5	-73.5
-65	-66.5	-63.5
-45	-46.5	-43.5
-25	-26.5	-23.5
-10	-11.5	-8.5

- (29) Reduce output of signal generator No.2 and disconnect from equipment setup.
- (30) Set signal generator No.1 for an output frequency of 455 kHz at an output level of 3 dB.
- (31) Press TI keys as listed in (a) through (l) below:
- (a) **BLUE.**
 - (b) **INSTR PRESET.**
 - (c) **DATA 100.**
 - (d) **DATA MHz.**
 - (e) **DATA 24.0.**
 - (f) **DATA SPCL.**
 - (g) **DATA 3.1.**
 - (h) **DATA SPCL.**
 - (i) **DATA 24.1.**
 - (j) **DATA SPCL.**
 - (k) **DATA 49., MEASUREMENT S, 2.**
 - (l) **DATA SPCL.**
- (32) Adjust signal generator No.1 output level for a TI indication of 2.500.
- (33) Decrease signal generator No.1 output level by 5 dB.
- (34) Divide signal generator No.1 displayed level by 1.406 and record the result.
- (35) Press TI keys as listed in (a) through (h) below:
- (a) **DATA 0.390.**
 - (b) **DATA SPCL.**
 - (c) **DATA 0.3, MEASUREMENT S, 4, MEASUREMENT S, 4.**
 - (d) **DATA SPCL.**
 - (e) **DATA 0.3, MEASUREMENT S, 30.**
 - (f) **DATA SPCL.**
 - (g) **DATA 49., MEASUREMENT S, 2.**
 - (h) **DATA SPCL.**
- (36) Adjust signal generator No.1 output level for a TI indication of 1.000.

- (37) Decrease signal generator No.1 output level by 5 dB.
- (38) Press TI keys as listed in (a) through (d) below:
 - (a) **DATA 0.3, MEASUREMENT S, 4, MEASUREMENT S, 3.**
 - (b) **DATA SPCL.**
 - (c) **DATA 49., MEASUREMENT S, 2.**
 - (d) **DATA SPCL.**
- (39) Multiply TI indication by number recorded in (34) above.
- (40) The computed result should be within limits specified in first row of table 28 below.
- (41) Repeat technique of (37) through (39) above using signal generator output levels and TI special functions listed in table 28 below.

Table 28. IF Gain Accuracy

Signal generator output level decrease (dB)	Test instrument	Calculated result	
	Special function data key strokes	Limit	
		Min	Max
5	0.3, MEASUREMENT S, 4, MEASUREMENT S, 3, SPCL, 49., MEASUREMENT S, 2, SPCL	0.944	1.059
5	0.3, MEASUREMENT S, 4, MEASUREMENT S, 1, SPCL, 49., MEASUREMENT S, 2, SPCL	0.944	1.059
5	0.3, MEASUREMENT S, 47, SPCL, 49., MEASUREMENT S, 2, SPCL	0.944	1.059
5	0.3, MEASUREMENT S, 4, MEASUREMENT S, 4, SPCL, 0.391, SPCL, 49., MEASUREMENT S, 2, SPCL	0.944	1.059
0	0.392, SPCL, 49., MEASUREMENT S, 2, SPCL	0.944	1.059
0	0.394, SPCL, 49., MEASUREMENT S, 2, SPCL	0.944	1.059
0	0.394, SPCL, 0.3, MEASUREMENT S, 31, SPCL, 49., MEASUREMENT S, 2, SPCL	0.944	1.059

(42) Reduce all outputs to minimum and disconnect equipment setup.

b. Adjustments. None

18. Power Supply

a. Performance Check

NOTE

Do not perform power supply adjustments if all other parameters are within tolerance.

TB 9-6625-2343-50

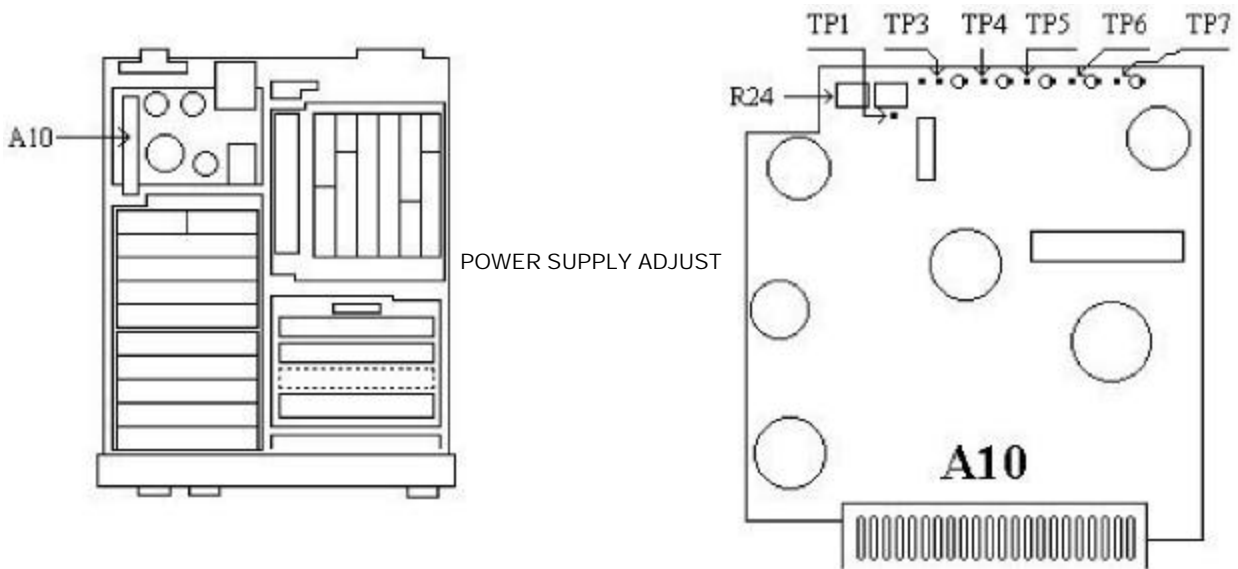

Figure 19. A10 board.

- (1) Connect digital multimeter between TP1 (fig. 19) (ground) and TP3 (fig. 19) (positive), and set digital multimeter to read V dc.
- (2) If digital multimeter indication is not between 14.99 and 15.01 V dc perform **b** below.
- (3) Move positive lead from TP3 to TP4 (fig. 19) and verify digital multimeter indicates between -15.2 and -14.8V dc.
- (4) Move positive lead from TP4 to TP5 (fig. 19) and verify digital multimeter indicates between 4.9 and 5.2 V dc for serial number 2305A to 2616A and between 5.1 and 5.2 V dc for serial number 2618A and above.
- (5) Move positive lead from TP5 to TP6 (fig. 19) and verify digital multimeter indicates between -4.9 and -5.2 V dc for serial number 2305A to 2616A and between -5.4 and -4.9 V dc for serial number 2618A and above.
- (6) Move positive lead from TP6 to TP7 (fig. 19) and verify digital multimeter indicates between 40.5 and 42.5 V dc.
- (7) Disconnect digital multimeter from A10 board.

(8) Connect digital multimeter to A13TP10 (fig. 20) (positive) and A13TP15 GND (fig. 20) (negative).

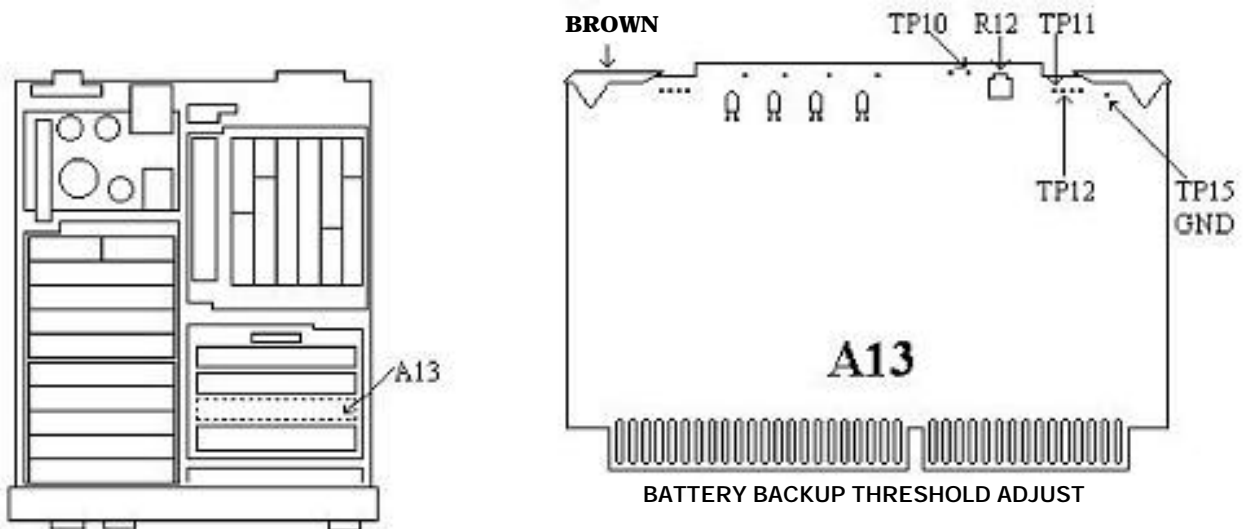

Figure 20. A13 board.

(9) Measure and record dc voltage as level No.1.

(10) Move positive lead from A13TP10 to A13TP12 (fig. 20) and record dc voltage as level No. 2.

(11) Calculate 2/5 of level No. 1 and 1/6 of level No. 2.

(12) Multiply the lowest voltage calculated in (11) above by 0.95 and record as threshold.

(13) Move positive lead from A13TP12 to A13TP11 (fig. 20) and adjust A13R12 (fig. 20) until digital multimeter indicates within $\pm 0.05V$ of threshold value. (R)

(14) Disconnect equipment setup.

b. Adjustments. Adjust A10R24 (fig. 19) for a digital multimeter indication of 15 V ± 0.01 V dc. (R)

19. Final Procedure

a. Deenergize and disconnect all equipment.

b. Annotate and affix DA label/form in accordance with TB 750-25.

THESE ARE THE INSTRUCTIONS FOR SENDING AN ELECTRONIC 2028

The following format must be used if submitting an electronic 2028. The subject line must be exactly the same and all fields must be included; however, only the following fields are mandatory: 1, 3, 4, 5, 6, 7, 8, 9, 10, 13, 15, 16, 17, and 27.

From: "Whoever" whoever@redstone.army.mil

To: <2028@redstone.army.mil

Subject: DA Form 2028

1. **From:** Joe Smith
2. **Unit:** Home
3. **Address:** 4300 Park
4. **City:** Hometown
5. **St:** MO
6. **Zip:** 77777
7. **Date Sent:** 19-Oct-93
8. **Pub No:** TB 9-6625-xxxx-35
9. **Pub Title:** Calibration Procedure for ...
10. **Publication Date:**
11. **Change Number:**
12. **Submitted Rank:** MSG
13. **Submitter Fname:** Joe
14. **Submitter Mname:** T
15. **Submitter Lname:** Smith
16. **Submitter Phone:** (123) 123-1234
17. **Problem:** 1
18. **Page:** 2
19. **Paragraph:** 3
20. **Line:** 4
21. **NSN:** 5
22. **Reference:** 6
23. **Figure :** 7
24. **Table:** 8
25. **Item:** 9
26. **Total:** 123
27. **Text:**

This is the text for the problem below line 27.

TB 9-6625-2343-50

By Order of the Secretary of the Army:

Official:

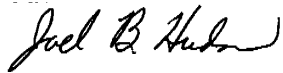

JOEL B. HUDSON

*Administrative Assistant to the
Secretary of the Army*

0313402

JOHN M. KEANE
*General, United States Army
Acting Chief of Staff*

Distribution:

To be distributed in accordance with IDS No. RLC-1500, 2 January 2003, requirements for calibration procedure TB 9-6625-2343-50.

TB 9-6625-2343-50

PIN: 080825-000